

KIT DRENAGGIO PLURY
contropressione
MAX 15 BAR

PLURY	W1 9.0 TONS 1.0 - 2.0	W1 15.0 TONS 1.5 - 4.0	W1 15.0 TONS 1.5 - 4.0	W1 15.0 TONS 1.5 - 4.0	W1 27.0 TONS 4.0 - 6.5	W1 27.0 TONS 4.0 - 6.5	W1 27.0 TONS 4.0 - 6.5
A (mm)	480	525	525	525	680	680	680
B (mm)	366	430	430	430	540	540	540
C (mm)	210	210	210	210	272	272	272
D (mm)	290	290	290	290	395	395	395
Peso (Kg)	72	105	105	105	187	187	187
Motore (CC)	11	11	14	17	21	27	32
Portata Olio (L/Min)	23	23	31	37	45	57	69
Pressione (BAR)	200/220	200/220	200/220	200/220	200/220	200/220	200/220
Giri / min' (RPM)	2.130	2.130	2.153	2.173	2.133	2.111	2.143
Forza centrifuga (kN)	9	15	15	15	27	27	27
Frequenza Vibrazione Hertz	35	36	36	36	36	36	36
Contro pres. max (BAR)	15	15	15	15	15	15	15

PLURY	W1 40.0 TONS 5.0 - 6.5	W1 40.0 TONS 5.0 - 6.5	W1 40.0 TONS 5.0 - 6.5	W1 65.0 TONS 7.0 - 15.0	W1 65.0 TONS 7.0 - 15.0	W1 65.0 TONS 7.0 - 15.0	W1 95.0 TONS 8.0 - 22.0	W1 95.0 TONS 8.0 - 22.0	W1 95.0 TONS 8.0 - 22.0
A (mm)	680	680	680	840	840	840	840	840	840
B (mm)	540	540	540	615	615	615	670	670	670
C (mm)	272	272	272	332	332	332	332	332	332
D (mm)	395	395	395	515	515	515	515	515	515
Peso (Kg)	190	190	190	330	330	330	340	340	340
Motore (CC)	21	27	32	32	43	47	32	43	47
Portata Olio (L/Min)	45	57	69	69	93	101	69	93	101
Pressione (BAR)	200/220	200/220	200/220	200/220	200/220	200/220	200/220	200/220	200/220
Giri / min' (RPM)	2.133	2.111	2.143	2.133	2.111	2.143	2.133	2.111	2.143
Forza centrifuga (kN)	40	40	40	65	65	65	95	95	95
Frequenza Vibrazione Hertz	36	36	36	36	36	36	36	36	36
Contro pres. max (BAR)	15	15	15	15	15	15	15	15	15

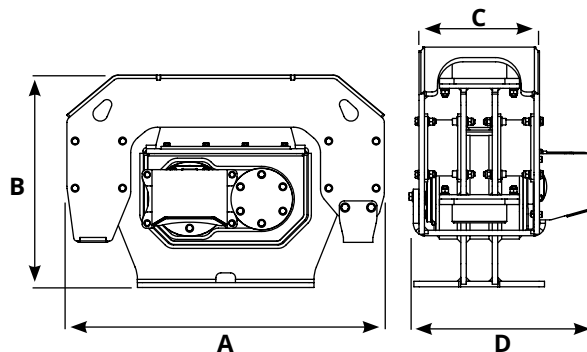



KIT DRENAGGIO PLURY
contropressione
MAX 15 BAR

PLURY	W2 60.0	W2 60.0	W2 60.0	W2 80.0	W2 80.0	W2 80.0	W2 100.0	W2 100.0	W2 100.0
	TONS 8.0 - 14.0	TONS 8.0 - 14.0	TONS 8.0 - 14.0	TONS 10.0 - 15.0	TONS 10.0 - 15.0	TONS 10.0 - 15.0	TONS 12.0 - 18.0	TONS 12.0 - 18.0	TONS 12.0 - 18.0
A (mm)	970	970	970	970	970	970	1030	1030	1030
B (mm)	650	650	650	650	650	650	735	735	735
C (mm)	330	330	330	330	330	330	395	395	395
D (mm)	490	490	490	490	490	490	560	560	560
Peso (Kg)	353	353	353	362	362	362	525	525	525
Motore (CC)	32	43	47	32	43	47	43	47	51
Portata Olio (L/Min)	69	93	101	69	93	101	93	100	110
Pressione (BAR)	200/220	200/220	200/220	200/220	200/220	200/220	200/220	200/220	200/220
Frequenza Vibrazione (RPM)	2.133	2.148	2.143	2.133	2.148	2.143	2.143	2.149	2.157
Forza centrifuga (Kn)	60	60	60	80	80	80	100	100	100
Hertz	36	36	36	36	36	36	36	36	36
Contro pres. max (BAR)	15	15	15	15	15	15	15	15	15

PLURY	W2 120.0	W2 120.0	W2 120.0	W2 150.0	W2 180.0
	TONS 14.0 - 20.0	TONS 14.0 - 20.0	TONS 14.0 - 20.0	TONS 18.0 - 35.0	TONS 20.0 - 40.0
A (mm)	1030	1030	1030	1220	1220
B (mm)	735	735	735	920	920
C (mm)	395	395	395	440	440
D (mm)	560	560	560	710	710
Peso (Kg)	533	533	533	827	837
Motore (CC)	43	47	51	63	63
Portata Olio (L/Min)	93	100	110	135	135
Pressione (BAR)	200/220	200/220	200/220	250/300	250/300
Frequenza Vibrazione (RPM)	2.143	2.149	2.157	2.143	2.143
Forza centrifuga (Kn)	120	120	120	150	180
Hertz	36	36	36	36	36
Contro pres. max (BAR)	15	15	15	15	15

GRAPPLE

PINZA LEGNO CON BATTIPALO

- > Progettata per la vibroinfiltrazione ed estrazione di pali in legno, cemento e acciaio
- > Adatta al contenimento di frane, banchine e argini
- > Costruzione di impianti di vigneti, frutteti e recinzioni
- > Una combinazione fondamentale, che trova impiego nella manutenzione del territorio e in agricoltura

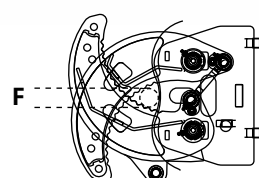
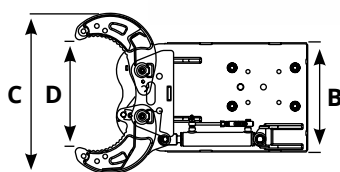
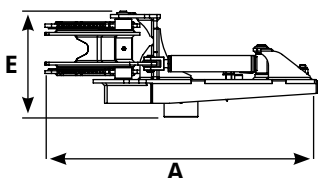

Model	A mm	B mm	C mm	D mm	E mm	F Ø mm	Kg.	Model. PLURY
GRAPPLE 1/4 ton	810	380	560	375	310	35	75	W1 9.0 W1 15.0
GRAPPLE 4/6.5 ton	1090	460	665	425	420	55	159	W1 27.0 W1 40.0
GRAPPLE 7/15 ton	1575	705	870	560	520	140	365	W1 65.0 W2 60.0 W2 80.0
GRAPPLE 8/20 ton	1590	705	870	570	520	140	375	W1 95.0 W2 100.0 W2 120.0
GRAPPLE 18/40 ton	1730	705	870	560	530	140	380	W2 150.0 W2 180.0

Portata olio (L/Min) 10

Pressione (BAR) 200



La Grapple ha possibilità di montare la campana personalizzata, disponibile in vari diametri a seconda delle proprie esigenze. La campana è compresa nel prezzo della Grapple.

Model	A mm	B mm	C mm	Kg	Model. PLURY
BELL 150 - 1/4 ton	150	200	125	15	W1 9.0 W1 15.0
BELL 200 - 1/4 ton	200	250	125	20	W1 9.0 W1 15.0
BELL 150 - 4/6.5 ton	150	200	105	11	W1 27.0 W1 40.0
BELL 200 - 4/6.5 ton	200	250	125	22	W1 27.0 W1 40.0
BELL 250 - 4/6.5 ton	250	300	145	28	W1 27.0 W1 40.0
BELL 150 - 7/40 ton	150	200	105	17	W1 65.0 W1 95.0 W2 60.0 W2 80.0 W2 100.0 W2 120.0 W2 150.0 W2 180.0
BELL 200 - 7/40 ton	200	250	105	20	W1 65.0 W1 95.0 W2 60.0 W2 80.0 W2 100.0 W2 120.0 W2 150.0 W2 180.0
BELL 250 - 7/40 ton	250	300	125	22	W1 65.0 W1 95.0 W2 60.0 W2 80.0 W2 100.0 W2 120.0 W2 150.0 W2 180.0
BELL 300 - 7/40 ton	300	350	180	43	W1 65.0 W1 95.0 W2 60.0 W2 80.0 W2 100.0 W2 120.0 W2 150.0 W2 180.0
BELL 350 - 7/40 ton	350	400	180	50	W1 65.0 W1 95.0 W2 60.0 W2 80.0 W2 100.0 W2 120.0 W2 150.0 W2 180.0

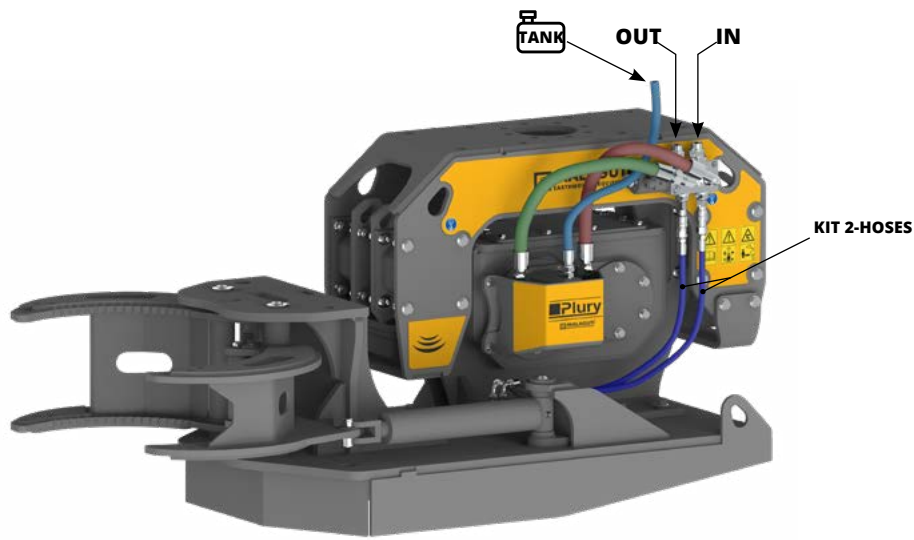

Model KIT	KIT IDRAULICI	Model. PLURY	Motor (cc)	Cod.
KIT A - PLURY	2-HOSES VALVE KIT 12Volt	W1 9.0 W1 15.0	11	HII0201013
KIT B - PLURY	2-HOSES VALVE KIT 12Volt	W1 27.0 W1 40.0	21 27 32	HII0201006
KIT C - PLURY	2-HOSES VALVE KIT 24Volt	W1 27.0 W1 40.0	21 27 32	HII0201035
KIT D - PLURY	2-HOSES VALVE KIT 12Volt	W1 65.0 W1 95.0 W2 60.0 W2 80.0 W2 100.0 W2 120.0	32 43 47 51	HII0201010
KIT E - PLURY	2-HOSES VALVE KIT 24Volt	W1 65.0 W1 95.0 W2 60.0 W2 80.0 W2 100.0 W2 120.0	32 43 47 51	HII0201037
KIT F - PLURY	2-HOSES VALVE KIT 12Volt	W2 150.0 W2 180.0	63	HII0201012
KIT G - PLURY	2-HOSES VALVE KIT 24Volt	W2 150.0 W2 180.0	63	HII0201038



Model	Model. PLURY	Cod.
A - 2 TUBI GRAPPLE	W1 9.0 W1 15.0	HII0201020
B - 2 TUBI GRAPPLE	W1 27.0 W1 40.0	HII0201022
C - 2 TUBI GRAPPLE	W1 65.0 W1 95.0 W2 60.0 W2 80.0	HII0201024
D - 2 TUBI GRAPPLE	W2 100.0 W2 120.0	HII0201026
C - 2 TUBI GRAPPLE	W2 150.0 W2 180.0	HII0201028



Model	Cod.
KIT ELETTRICO	C030201020

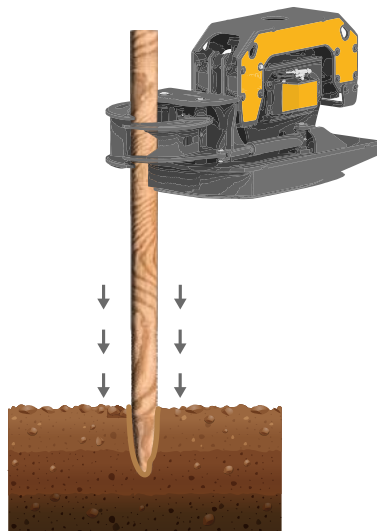

OPTIONAL GRAPPLE KIT

OPTIONAL CEMENTO-ACCIAIO

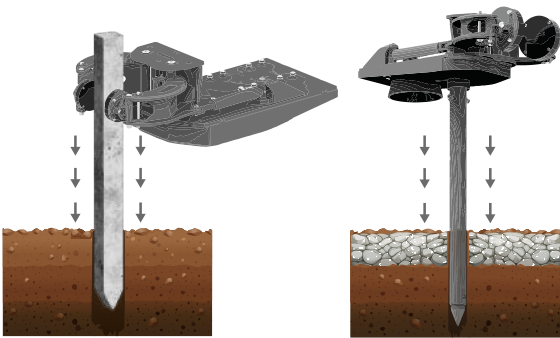
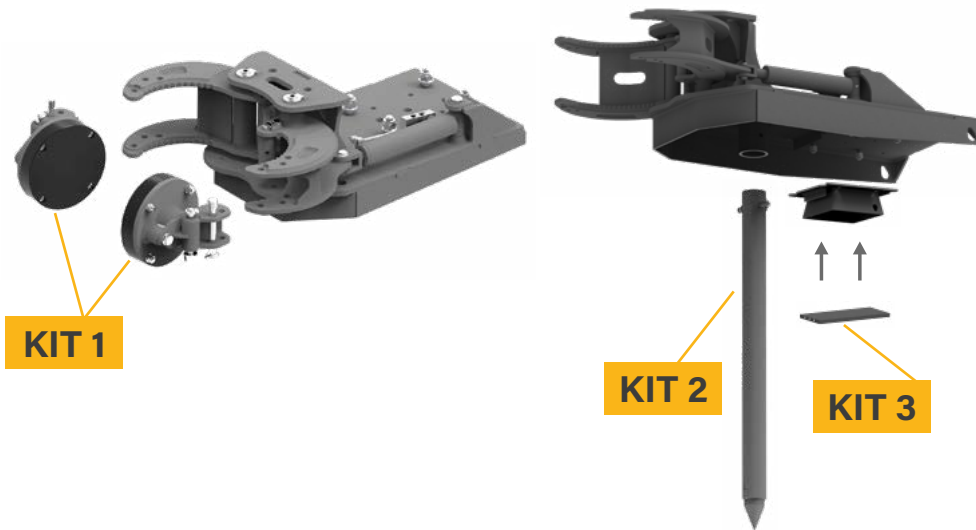

KIT 1

- › Accessorio per pinza adatto alla vibroinfissione ed estrazione di pali in cemento e acciaio

KIT 2

- › Punta preforo adatta ad eseguire un preforo nel terreno duro
- › Indicata per la vibroinfissione dei pali in cemento

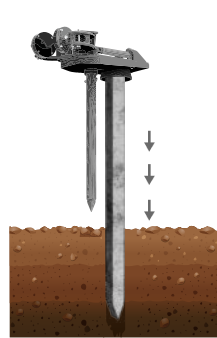

KIT 3

- › Accessorio in gomma ammortizzante adatto nella vibroinfissione di pali in cemento, evitando il danneggiamento del palo stesso

OPTIONAL PIASTRA DENTATA

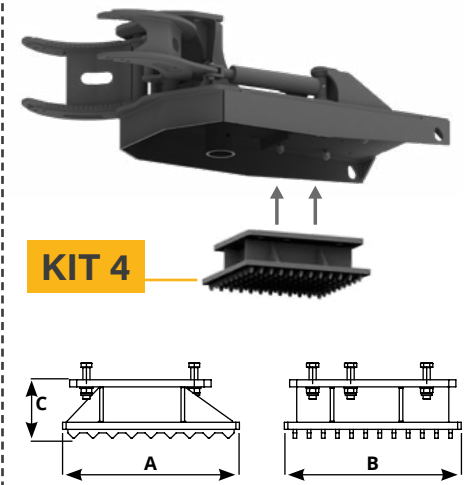

KIT 4

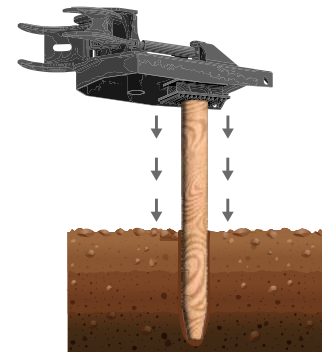

KIT 4

- › Piastra dentata montata al posto della campana per vibroinfissione di pali in legno di diverso diametro

Model	A mm	B mm	C mm	Kg.	Model. GRAPPLE
KIT 1 - 1/4 ton	/	/	/	16	GRAPPLE 1/4 ton
KIT 2 - 1/6.5 ton	/	/	/	22	
KIT 3 for Bell	a seconda del tipo di Bell				
KIT 4 - 1/4 ton	335	270	120	23	

Model	A mm	B mm	C mm	Kg.	Model. GRAPPLE
KIT 1 - 4/6.5 ton	/	/	/	20	GRAPPLE 4/6.5 ton
KIT 2 - 1/6.5 ton	/	/	/	22	
KIT 3 for Bell	a seconda del tipo di Bell				
KIT 4 - 4/6.5 ton	350	400	130	44	

Model	A mm	B mm	C mm	Kg.	Model. GRAPPLE
KIT 1 - 7/40 ton	/	/	/	24	GRAPPLE 7/15 ton
KIT 2 - 7/20 ton	/	/	/	27	
KIT 3 for Bell	a seconda del tipo di Bell				GRAPPLE 8/20 ton
KIT 4 - 7/20 ton	500	500	165	90	

Model	A mm	B mm	C mm	Kg.	Model. GRAPPLE
KIT 1 - 7/40 ton	/	/	/	24	GRAPPLE 18/40 ton
KIT 2 - 18/40 ton	/	/	/	43	
KIT 3 for Bell	a seconda del tipo di Bell				
KIT 4 - 18/40 ton	540	500	175	100	