

# ONE WHEEL

## SINGOLA RUOTA

- > Ideale per lavori di compattazione su scavi stretti
- > Permette alla ruota di arrivare in profondità
- > Particolarmente indicata per la messa a terra della fibra e sottoservizi

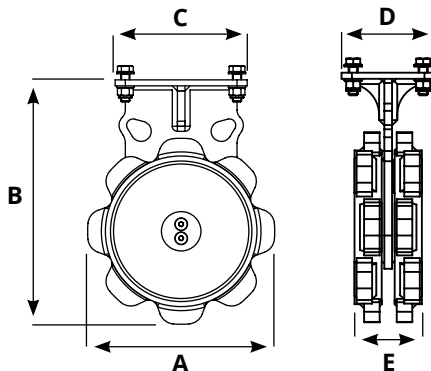

Model	A mm	B mm	C mm	D mm	E mm	Kg.	Model. PLURY
ONE WHEEL 130 1/4.5 ton	370	485	260	180	130	46	<b>W1 9.0   W1 15.0</b>
ONE WHEEL 200 1/4.5 ton	370	485	260	180	200	58	<b>W1 9.0   W1 15.0</b>
ONE WHEEL 200 4/12 ton	480	600	420	250	200	95	<b>W1 27.0   W1 40.0</b>
ONE WHEEL 300 4/12 ton	480	600	420	250	300	110	<b>W1 27.0   W1 40.0</b>
ONE WHEEL 270 8/40 ton	710	830	540	360	270	212	<b>W1 65.0   W1 95.0   W2 60.0 W2 80.0   W2 100.0   W2 120.0 W2 150.0   W2 180.0</b>
ONE WHEEL 350 8/40 ton	710	830	540	360	350	243	<b>W1 65.0   W1 95.0   W2 60.0 W2 80.0   W2 100.0   W2 120.0 W2 150.0   W2 180.0</b>

- > Tramite gli ATTACCHI MACCHINA la ruota può essere montata direttamente sulla macchina da lavoro senza propulsore

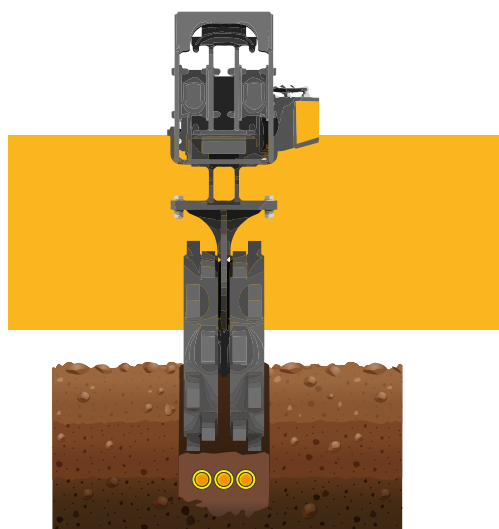
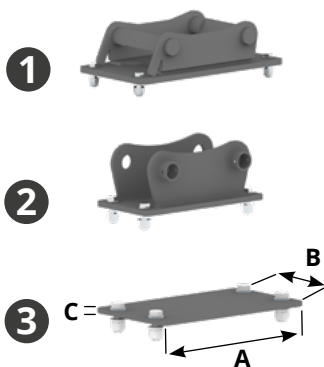

Model	A mm	B mm	C mm	Kg.
ADAPTER FOR QUICK COUPLING 1/4.5 ton	/	/	/	/
ADAPTER FOR QUICK COUPLING 4/12 ton	/	/	/	/
ADAPTER FOR QUICK COUPLING 8/14 ton	/	/	/	/
ADAPTER FOR QUICK COUPLING 12/25 ton	/	/	/	/
ADAPTER FOR QUICK COUPLING 18/40 ton	/	/	/	/
FIXED COUPLING MACHINE 1/4.5 ton	/	/	/	/
FIXED COUPLING MACHINE 4/12 ton	/	/	/	/
FIXED COUPLING MACHINE 8/14 ton	/	/	/	/
FIXED COUPLING MACHINE 12/25 ton	/	/	/	/
FIXED COUPLING MACHINE 18/40 ton	/	/	/	/
BOLTED PLATE MACHINE COUPLING 1/2 ton	390	195	10	7
BOLTED PLATE MACHINE COUPLING 1/4.5 ton	410	235	10	8.5
BOLTED PLATE MACHINE COUPLING 4/12 ton	470	280	15	16.5
BOLTED PLATE MACHINE COUPLING 8/14 ton	640	340	15	29
BOLTED PLATE MACHINE COUPLING 12/25 ton	710	400	20	48
BOLTED PLATE MACHINE COUPLING 18/40 ton	920	450	20	70