

TORNADO

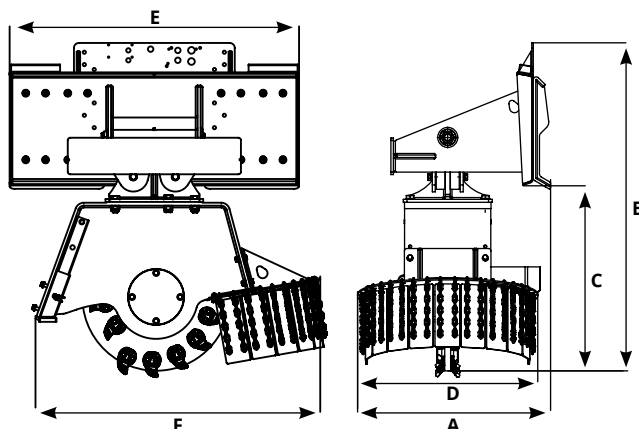

FRESACEPPI FRONTALE TRASVERSALE per SKID LOADER e WHEEL LOADER



TORNADO 2FT	Tornado 2FT 350	Tornado 2FT 450	Tornado 2FT 600	Tornado 2FT 600 PLUS
A (mm)	720	720	780	780
B (Ømm)	1060	1160	1325	1325
C (mm)	480	570	750	750
D (mm)	610	610	730	730
E (mm)	1170	1170	1170	1170
F (mm)	760	900	1150	1150
Motore (CC)	12 18 25 28 32	25 28 32	45 50 63	80
Portata Olio (L/Min)	16 24 32 36 42	32 36 42	56 64 80	110
RPM	1330 1330 1280 1280 1315	1280 1280 1315	1290 1300 1300	1375
Peso (Kg)	246	300	408	408
Numero denti	16	20	28	28
Pressione (BAR)	250	250	250	250
Contro pressione Max.	15	15	15	15

KIT IDRAULICI

KIT IDRAULICO 2 TUBI + DRENAGGIO CON REGOLAZIONE DI FLUSSO MOTORE

KIT IDRAULICO 2 TUBI + DRENAGGIO (la regolazione è gestita dalla macchina operatrice)

Model

COUPLING TO LOADER
supplemento per PALE

