

TWIN WHEEL

DOPPIA RUOTA

- > Ideale per lavori di compattazione su scavi stretti e curvi
- > Permette alla ruota di arrivare in profondità
- > Particolarmente indicata per la messa a terra della fibra e sottoservizi

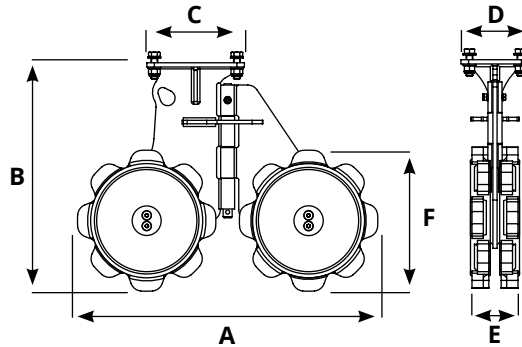

Model	A mm	B mm	C mm	D mm	E mm	F mm	Kg.	Model. PLURY
TWIN WHEEL 130 1/4.5 ton	805	596	260	370	130	370	86	W1 9.0 W1 15.0
TWIN WHEEL 200 1/4.5 ton	805	596	260	370	200	370	115	W1 9.0 W1 15.0
TWIN WHEEL 200 4/12 ton	1065	715	420	250	200	480	185	W1 27.0 W1 40.0
TWIN WHEEL 300 4/12 ton	1065	715	420	250	300	480	230	W1 27.0 W1 40.0
TWIN WHEEL 270 8/40 ton	1540	890	540	360	270	710	408	W1 65.0 W1 95.0 W2 60.0 W2 80.0 W2 100.0 W2 120.0 W2 150.0 W2 180.0
TWIN WHEEL 3508/40 ton	1540	890	540	360	350	710	442	W1 65.0 W1 95.0 W2 60.0 W2 80.0 W2 100.0 W2 120.0 W2 150.0 W2 180.0

- > Tramite gli ATTACCHI MACCHINA la ruota può essere montata direttamente sulla macchina da lavoro senza propulsore

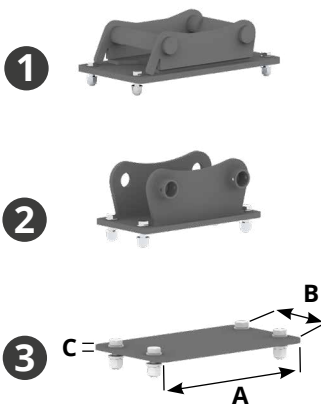

	Model	A mm	B mm	C mm	Kg.
1	ADAPTER FOR QUICK COUPLING 1/4.5 ton	/	/	/	/
	ADAPTER FOR QUICK COUPLING 4/12 ton	/	/	/	/
1	ADAPTER FOR QUICK COUPLING 8/14 ton	/	/	/	/
	ADAPTER FOR QUICK COUPLING 12/25 ton	/	/	/	/
	ADAPTER FOR QUICK COUPLING 18/40 ton	/	/	/	/
2	FIXED COUPLING MACHINE 1/4.5 ton	/	/	/	/
	FIXED COUPLING MACHINE 4/12 ton	/	/	/	/
	FIXED COUPLING MACHINE 8/14 ton	/	/	/	/
	FIXED COUPLING MACHINE 12/25 ton	/	/	/	/
	FIXED COUPLING MACHINE 18/40 ton	/	/	/	/
	BOLTED PLATE MACHINE COUPLING 1/2 ton	390	195	10	7
	BOLTED PLATE MACHINE COUPLING 1/4.5 ton	410	235	10	8.5
3	BOLTED PLATE MACHINE COUPLING 4/12 ton	470	280	15	16.5
	BOLTED PLATE MACHINE COUPLING 8/14 ton	640	340	15	29
	BOLTED PLATE MACHINE COUPLING 12/25 ton	710	400	20	48
	BOLTED PLATE MACHINE COUPLING 18/40 ton	920	450	20	70

