



 **Plury**<sup>®</sup>

Eine einzige Maschine die  
**VERDICHTET,  
INFIX  
VORBOHRT  
UND SCHNEIDET**

#### **DREHWERK**

IN VERSCHIEDENEN TONNAGEN  
ERHÄLTlich

#### **MULTIFUNKTIONALES ZUBEHÖR**

UNSER ZUBEHÖR ERMÖGLICHT  
IHNEN KOMPACTE,  
VERSCHIEDENE GELÄNDEARTEN  
VORBOHREN  
UND EINTREIBEN VON PFÄHLEN  
UND SPUNDWÄNDE

#### **GROSSE AUSWAHL AN ZUBEHÖR**

DARAUF ABZIELEN,  
VERSCHIEDENE ARTEN VON  
ARBEITEN AUF DER BAUSTELLE  
ZU ERFÜLLEN

#### **VIELSEITIG**

WENN ES MIT EINER  
SCHNELLKUPPLUNG AUSGESTATTET  
IST, ERMÖGLICHT ES DEN WECHSEL  
ZUBEHÖR MIT EXTREMER  
GESCHWINDIGKEIT

<b>PLURY W1</b>	<b>7</b>
DREHWERK 1.0 - 22.0 TONS	
<b>PLURY W2</b>	<b>8</b>
DREHWERK 8.0 - 40.0 TONS	
<b>MACHINE ATTACHMENTS</b>	<b>9</b>
MASCHINENBEFESTIGUNG	
<b>MECHANICAL SLEWING</b>	<b>10</b>
MECHANISCHE RECHEN	
<b>ROTATORS</b>	<b>11</b>
ROTATIONSSYSTEME	
<b>HYDRAULICS SLEWING</b>	<b>12</b>
HYDRAULISCHE RECHEN	
<b>PLATE</b>	<b>13</b>
VERDICHTUNGSPLATTE	
<b>GRAPPLE</b>	<b>16</b>
HOLZGREIFER MIT PFAHLRAMME	
<b>OPTIONAL GRAPPLE KIT</b>	<b>18</b>
OPTION BETON - STAHL	
<b>BELL</b>	<b>23</b>
ZENTRIEREN VON PFÄHLEN	
<b>T-DRILLING + ADAPTER</b>	<b>24</b>
VORBOHRER	
<b>T-PLATE</b>	<b>25</b>
SCHMALE SOHLE - EINZELN SCHLITTEN	
<b>TWIN PLATE</b>	<b>27</b>
SCHMALE SOHLE - DOPPELSCHLITTEN	
<b>ONE WHEEL</b>	<b>28</b>
EINZELRAD	
<b>TWIN WHEEL</b>	<b>31</b>
DOPPELRAD	
<b>STORM WHEEL</b>	<b>32</b>
VERDICHTERRAD	
<b>ASPHALT CUTTER</b>	<b>34</b>
ASPHALTSCHNEIDER	
<b>SHEET PILE CLAMP</b>	<b>36</b>
ZANGE FÜR SPUNDWÄNDEN	
<b>H-BEAM CLAMP</b>	<b>38</b>
KLAMMER FÜR H-TRÄGER	
<b>PLURY KN</b>	<b>40</b>
DOPPEL VERDICHTERPLATTE ZUM FRONTANBAU	
<b>FRONT-MOUNTED ATTACHMENT PLURY</b>	<b>42</b>
EINZELNE FRONTBEFESTIGUNG FÜR PLURY	

# Plury<sup>®</sup>

 VIDEO

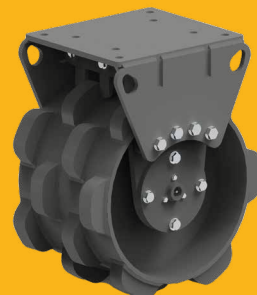
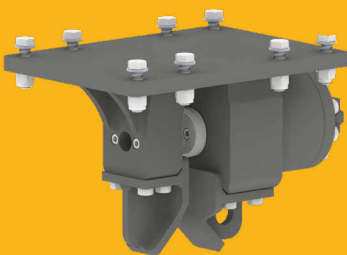
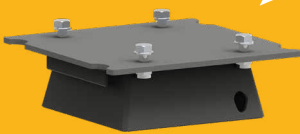
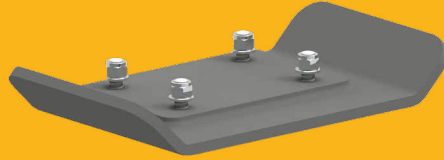
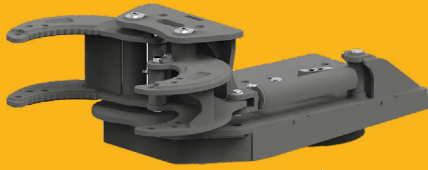

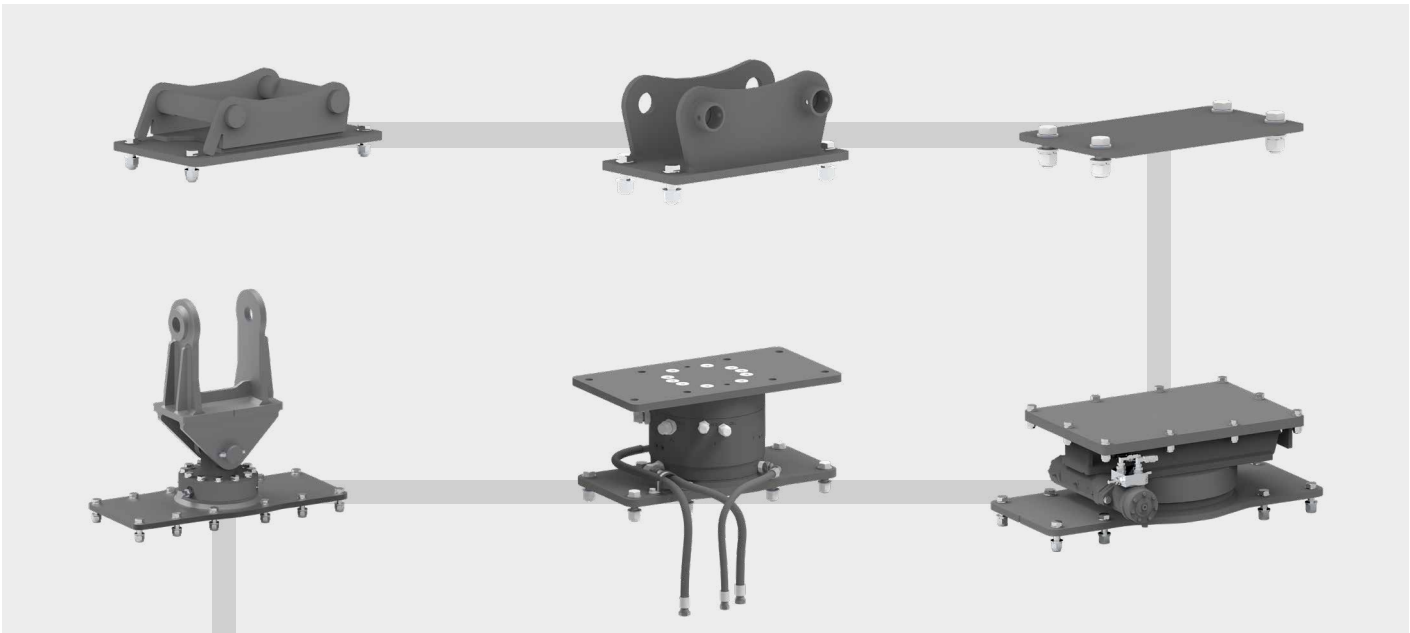

# Maschinenanschlüsse — und PLURY-Ausrüstungen

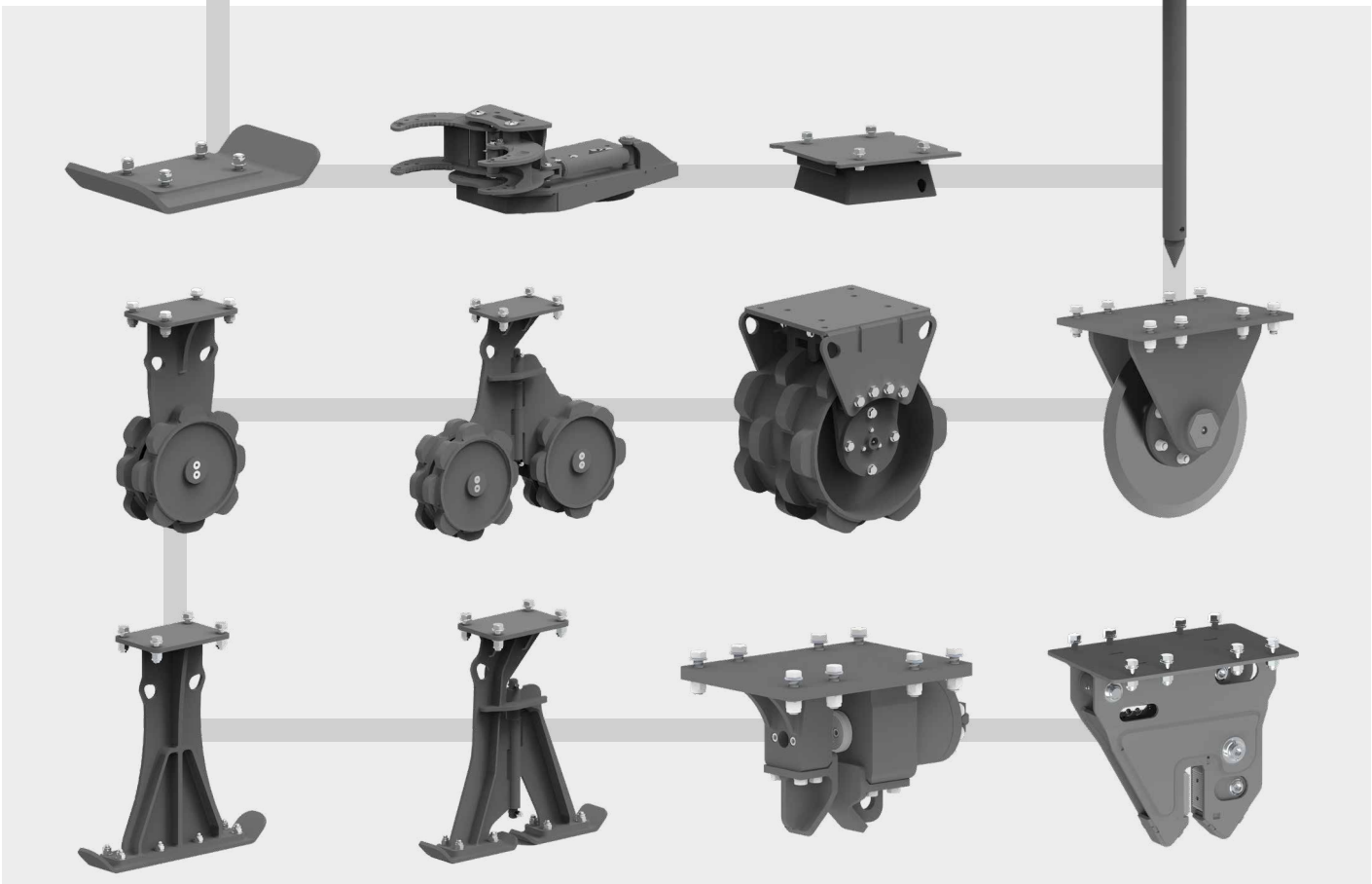

# PLURY-Zusammensetzung

## PLURY mit verschraubter Ausrüstung



## PLURY mit Ausrüstung, die über Schnellkupplung verbunden ist

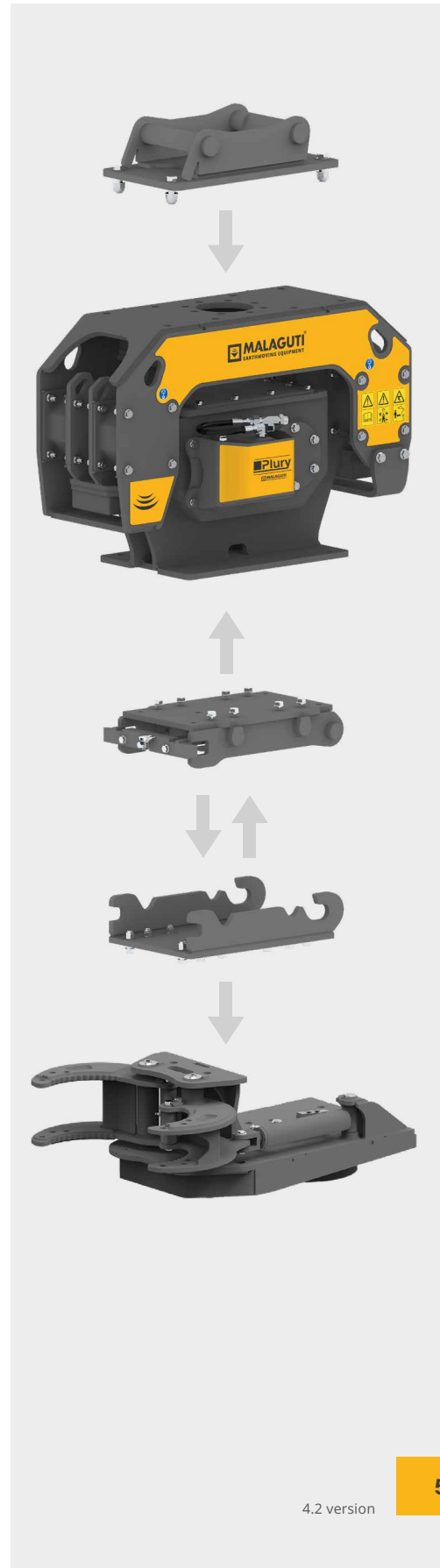

# UNTERSCHIED ZWISCHEN 1 UND 2 EXZENTERMASSEN

## PLURY W1

■ Vibrationsmasse

■ Richtkraft

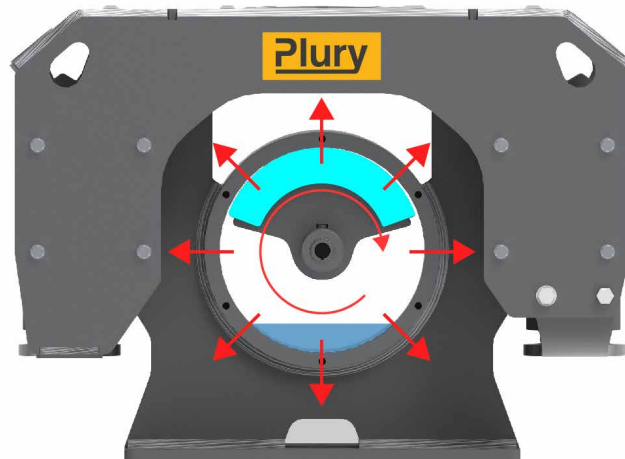

Radiale Vibration, die erzeugte Zentrifugalkraft verteilt sich radial in 360°

## PLURY W2

■ Vibrationsmasse

■ Richtkraft

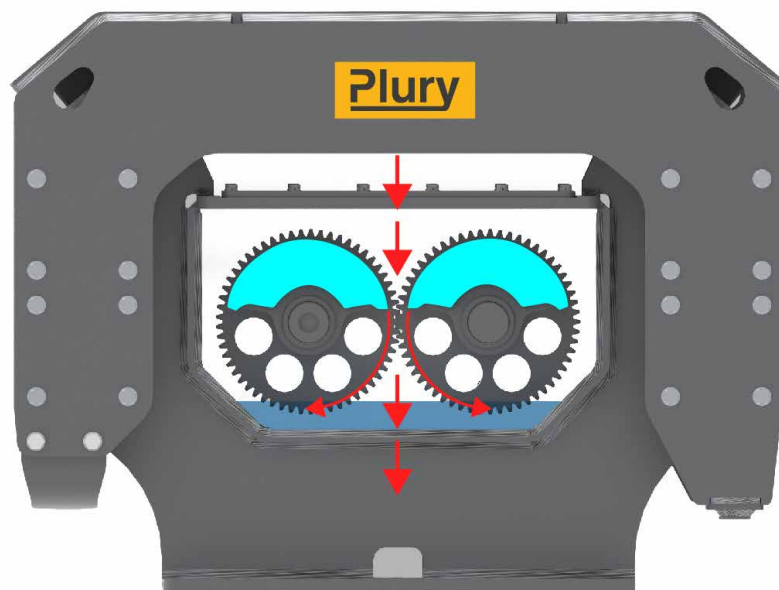

Sinusoidalvibration, sie vibriert vertikal von oben nach unten und konzentriert die Zentrifugalkraft in der Mitte

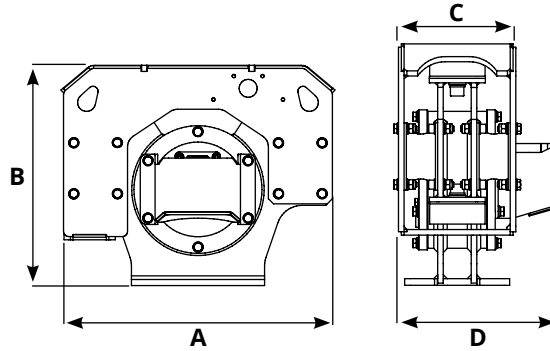

KIT DRAINAGE PLURY  
Max. Gegendruck  
15 BAR

PLURY	W1 9.0 TONS 1.0 - 2.0	W1 15.0 TONS 1.5 - 4.0	W1 15.0 TONS 1.5 - 4.0	W1 15.0 TONS 1.5 - 4.0	W1 27.0 TONS 4.0 - 6.5	W1 27.0 TONS 4.0 - 6.5	W1 27.0 TONS 4.0 - 6.5
A (mm)	480	525	525	525	680	680	680
B (mm)	366	430	430	430	540	540	540
C (mm)	210	210	210	210	272	272	272
D (mm)	290	290	290	290	395	395	395
Gewicht (Kg)	72	105	105	105	187	187	187
Motor (CC)	11	11	14	17	21	27	32
Öldurchsatz (L/Min)	23	23	31	37	45	57	69
Druck (BAR)	200/220	200/220	200/220	200/220	200/220	200/220	200/220
Vibrationsfrequenz (RPM)	2.130	2.130	2.153	2.173	2.133	2.111	2.143
Zentrifugalkraft (Kn)	9	15	15	15	27	27	27
Hertz	35	36	36	36	36	36	36
Max. Gegendruck (BAR)	15	15	15	15	15	15	15

PLURY	W1 40.0 TONS 5.0 - 6.5	W1 40.0 TONS 5.0 - 6.5	W1 40.0 TONS 5.0 - 6.5	W1 65.0 TONS 7.0 - 15.0	W1 65.0 TONS 7.0 - 15.0	W1 65.0 TONS 7.0 - 15.0	W1 95.0 TONS 8.0 - 22.0	W1 95.0 TONS 8.0 - 22.0	W1 95.0 TONS 8.0 - 22.0
A (mm)	680	680	680	840	840	840	840	840	840
B (mm)	540	540	540	670	670	670	670	670	670
C (mm)	272	272	272	332	332	332	332	332	332
D (mm)	395	395	395	515	515	515	515	515	515
Gewicht (Kg)	190	190	190	330	330	330	340	340	340
Motor (CC)	21	27	32	32	43	47	32	43	51
Öldurchsatz (L/Min)	45	57	69	69	93	101	69	93	101
Druck (BAR)	200/220	200/220	200/220	200/220	200/220	200/220	200/220	200/220	200/220
Vibrationsfrequenz (RPM)	2.133	2.111	2.143	2.133	2.111	2.143	2.133	2.111	2.143
Zentrifugalkraft (Kn)	40	40	40	65	65	65	95	95	95
Hertz	36	36	36	36	36	36	36	36	36
Max. Gegendruck (BAR)	15	15	15	15	15	15	15	15	15



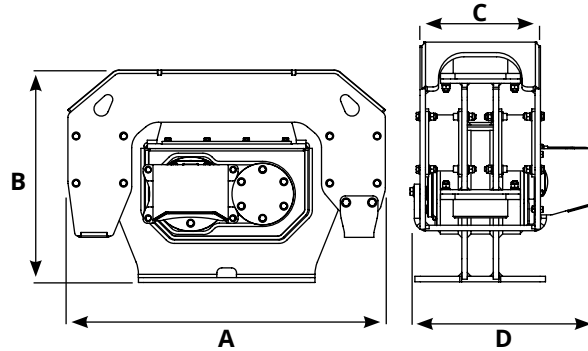

**KIT DRAINAGE PLURY**  
Max. Gegendruck  
15 BAR

PLURY	W2 60.0	W2 60.0	W2 60.0	W2 80.0	W2 80.0	W2 80.0	W2 100.0	W2 100.0	W2 100.0
	TONS 8.0 - 14.0	TONS 8.0 - 14.0	TONS 8.0 - 14.0	TONS 10.0 - 15.0	TONS 10.0 - 15.0	TONS 10.0 - 15.0	TONS 12.0 - 18.0	TONS 12.0 - 18.0	TONS 12.0 - 18.0
A (mm)	970	970	970	970	970	970	1030	1030	1030
B (mm)	650	650	650	650	650	650	735	735	735
C (mm)	330	330	330	330	330	330	395	395	395
D (mm)	490	490	490	490	490	490	560	560	560
Gewicht (Kg)	353	353	353	362	362	362	525	525	525
Motor (CC)	32	43	47	32	43	47	43	47	51
Öldurchsatz (L/Min)	69	93	101	69	93	101	93	100	110
Druck (BAR)	200/220	200/220	200/220	200/220	200/220	200/220	200/220	200/220	200/220
Vibrationsfrequenz (RPM)	2.133	2.148	2.143	2.133	2.148	2.143	2.143	2.149	2.157
Zentrifugalkraft (Kn)	60	60	60	80	80	80	100	100	100
Hertz	36	36	36	36	36	36	36	36	36
Max. Gegendruck (BAR)	15	15	15	15	15	15	15	15	15

PLURY	W2 120.0	W2 120.0	W2 120.0	W2 150.0	W2 180.0
	TONS 14.0 - 20.0	TONS 14.0 - 20.0	TONS 14.0 - 20.0	TONS 18.0 - 35.0	TONS 20.0 - 40.0
A (mm)	1030	1030	1030	1220	1220
B (mm)	735	735	735	920	920
C (mm)	395	395	395	440	440
D (mm)	560	560	560	710	710
Gewicht (Kg)	533	533	533	827	837
Motor (CC)	43	47	51	63	63
Öldurchsatz (L/Min)	93	100	110	135	135
Druck (BAR)	200/220	200/220	200/220	250/300	250/300
Vibrationsfrequenz (RPM)	2.143	2.149	2.157	2.143	2.143
Zentrifugalkraft (Kn)	120	120	120	150	180
Hertz	36	36	36	36	36
Max. Gegendruck (BAR)	15	15	15	15	15



# MACHINE ATTACHMENTS



Model	A mm	B mm	C mm	Kg.	Model. PLURY
ADAPTER FOR QUICK COUPLING 1/4 ton	/	/	/	/	W1 9.0   W1 15.0
ADAPTER FOR QUICK COUPLING 4/6.5 ton	/	/	/	/	W1 27.0   W1 40.0
ADAPTER FOR QUICK COUPLING 7/15 ton	/	/	/	/	W1 65.0   W2 60.0   W2 80.0
ADAPTER FOR QUICK COUPLING 8/20 ton	/	/	/	/	W1 95.0   W2 100.0   W2 120.0
ADAPTER FOR QUICK COUPLING 18/40 ton	/	/	/	/	W2 150.0   W2 180.0



Model	A mm	B mm	C mm	Kg.	Model. PLURY
FIXED COUPLING MACHINE 1/4 ton	/	/	/	/	W1 9.0   W1 15.0
FIXED COUPLING MACHINE 4/6.5 ton	/	/	/	/	W1 27.0   W1 40.0
FIXED COUPLING MACHINE 7/15 ton	/	/	/	/	W1 65.0   W2 60.0   W2 80.0
FIXED COUPLING MACHINE 8/20 ton	/	/	/	/	W1 95.0   W2 100.0   W2 120.0
FIXED COUPLING MACHINE 18/40 ton	/	/	/	/	W2 150.0   W2 180.0

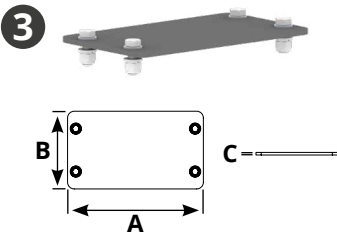

Model	A mm	B mm	C mm	Kg.	Model. PLURY
BOLTED PLATE MACHINE COUPLING 1/2 ton	390	195	10	7	W1 9.0
BOLTED PLATE MACHINE COUPLING 1.5/4 ton	410	235	10	8.5	W1 15.0
BOLTED PLATE MACHINE COUPLING 4/6.5 ton	470	280	15	16.5	W1 27.0   W1 40.0
BOLTED PLATE MACHINE COUPLING 7/15 ton	640	340	15	29	W1 65.0   W2 60.0   W2 80.0
BOLTED PLATE MACHINE COUPLING 8/20 ton	710	400	20	48	W1 95.0   W2 100.0   W2 120.0
BOLTED PLATE MACHINE COUPLING 18/40 ton	920	450	20	70	W2 150.0   W2 180.0

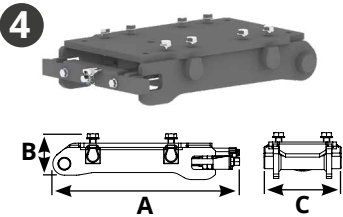

Model	A mm	B mm	C mm	Kg.	Model. PLURY
TOK QUICK COUPLER 1/4 ton	525	103	220	29	W1 9.0   W1 15.0
TOK QUICK COUPLER 4/6.5 ton	625	120	295	53	W1 27.0   W1 40.0
TOK QUICK COUPLER 7/40 ton	805	160	480	140	W1 65.0   W2 60.0   W2 80.0 W1 95.0   W2 100.0   W2 120.0 W2 150.0   W2 180.0

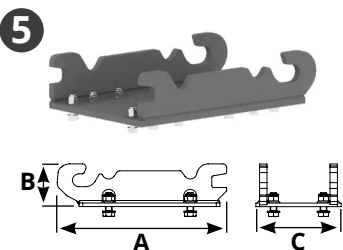

Model	A mm	B mm	C mm	Kg.	Model. PLURY
TOK ADAPTER 1/4 ton	460	120	230	19,5	W1 9.0   W1 15.0
TOK ADAPTER 4/6.5 ton	570	160	290	37	W1 27.0   W1 40.0
TOK ADAPTER 7/40 ton	750	175	475	88	W1 65.0   W2 60.0   W2 80.0 W1 95.0   W2 100.0   W2 120.0 W2 150.0   W2 180.0



# MECHANICAL SLEWING

## MECHANISCHE RECHEN

- > Der mechanische Rechen kann am Baggerarm schwenkbar montiert werden
- > Die mechanische Rotation ermöglicht es der Ausrüstung, sich um 120° in teilweiser Drehung um sich selbst zu drehen

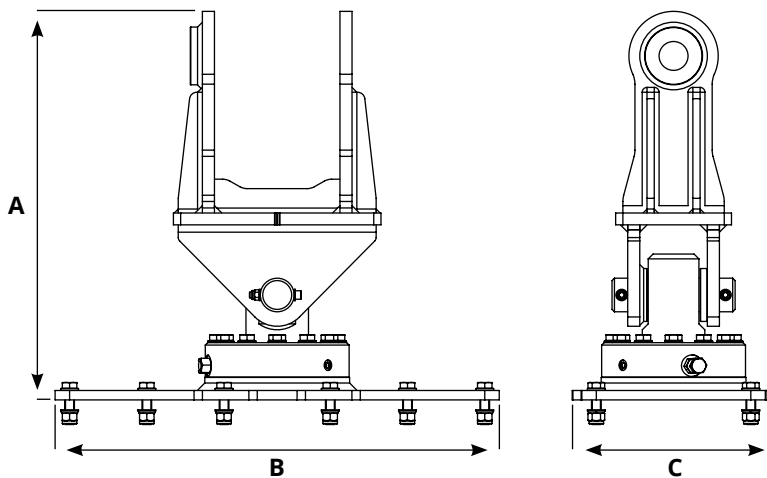
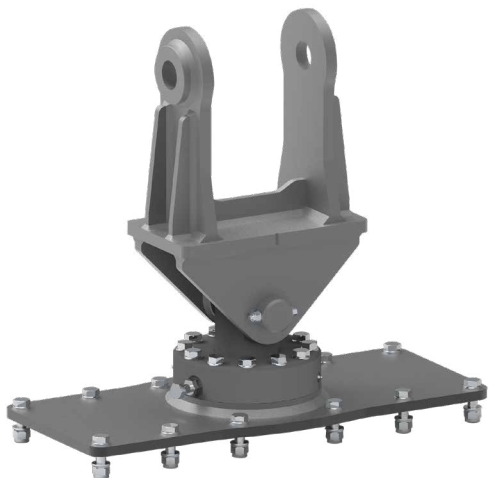

Model	A mm	B mm	C mm	Max Rotation	Kg.	Model. PLURY
<b>MECHANICAL SLEWING 18/40 ton</b>	920	805	420	120°	210	W2 150.0   W2 180.0



# ROTATORS

## ROTATIONSSYSTEME

- > Dadurch kann sich die Maschine in kontinuierlicher Rotation um 360° um sich selbst drehen
- > Der Rotor wird inklusive Röhren verkauft
- > Der Rotor kann nur mit nicht hydraulisch betätigten Anbaugeräten an der Plury montiert werden

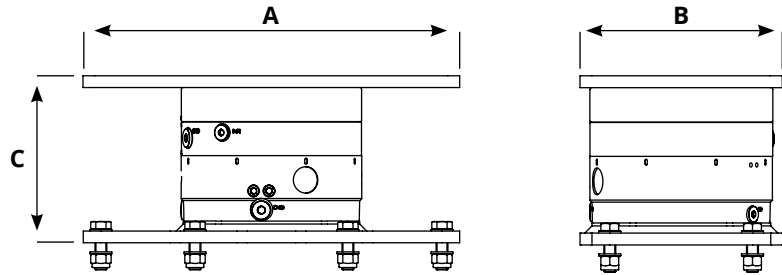

Model	A mm	B mm	C mm	Kg.	Model. PLURY
ROTATORS 1.5/4 ton	420	235	235	60	W1 15.0
ROTATORS 4/6.5 ton	480	290	265	120	W1 27.0   W1 40.0
ROTATORS 7/15 ton	640	340	285	161	W1 65.0   W1 95.0   W2 60.0   W2 80
ROTATORS 12/20 ton	710	400	285	180	W2 100.0   W2 120.0
ROTATORS 18/40 ton	920	420	340	300	W2 150.0   W2 180.0



# HYDRAULICS SLEWING

## HYDRAULISCHE RECHEN

- › Der hydraulische Rechen kann durch Anbringen am Bagger montiert werden
- › Die hydraulische Rotation ermöglicht es der Ausrüstung, sich um 320° in teilweiser Drehung um sich selbst zu drehen

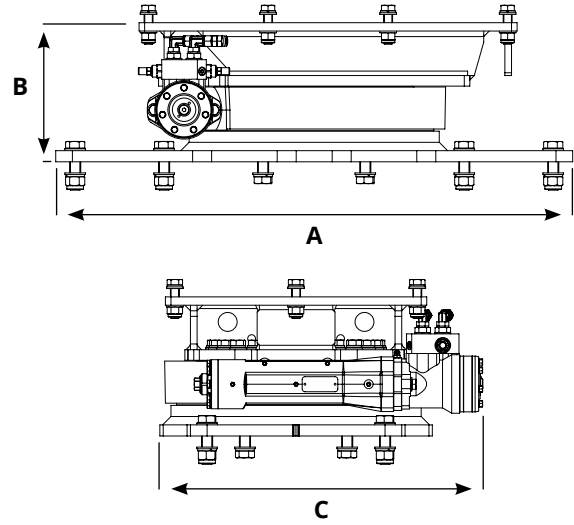
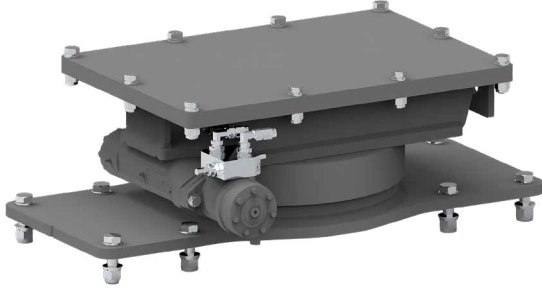

Model	A mm	B mm	C mm	Max Rotation	Kg.	Model. PLURY
HYDRAULICS SLEWING 7/15 ton	650	245	526	320°	170	W1 65.0   W1 95.0   W2 60.0   W2 80.0
HYDRAULICS SLEWING 12/20 ton	720	245	526	320°	175	W2 100.0   W2 120.0
HYDRAULICS SLEWING 18/40 ton	930	250	581	320°	260	W2 150.0   W2 180.0



# PLATE

## VERDICHTUNGSPLATTE

- › Entwickelt, um alle Arten von Oberflächen wie Gräben, Böden, Steilwände zu verdichten
- › Sie garantiert einen kompakten, homogenen und stabilen Boden, die lange hält
- › Sie ist in der Lage, in sehr schwierigen Positionen zu verdichten

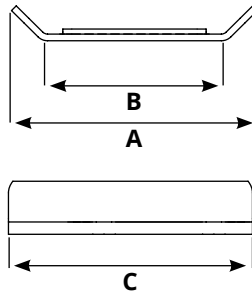

Model	A mm	B mm	C mm	Kg.	compaction kg cm2		Model. PLURY
<b>PLATE 300 1/4 ton</b>	550	400	300	30	W1 9.0 > 0.75	W1 15.0 > 1.25	W1 9.0   W1 15.0
<b>PLATE 400 1/4 ton</b>	550	400	400	40	W1 9.0 > 0.56	W1 15.0 > 0.93	W1 9.0   W1 15.0
<b>PLATE 590 1.5/4 ton</b>	550	400	590	59	W1 15.0 > 0.63		W1 15.0
<b>PLATE 690 1.5/4 ton</b>	550	400	690	69	W1 15.0 > 0.54		W1 15.0
<b>PLATE 400 4/6.5 ton</b>	700	500	400	60	W1 27.0 > 1.35	W1 40.0 > 2	W1 27.0   W1 40.0
<b>PLATE 500 4/6.5 ton</b>	700	500	500	75	W1 27.0 > 1.08	W1 40.0 > 1.6	W1 27.0   W1 40.0
<b>PLATE 690 4/6.5 ton</b>	700	500	690	100	W1 27.0 > 0.78	W1 40.0 > 1.15	W1 27.0   W1 40.0
<b>PLATE 790 4/6.5 ton</b>	700	500	790	115	W1 27.0 > 0.68	W1 40.0 > 1	W1 27.0   W1 40.0
<b>PLATE 890 4/6.5 ton</b>	700	500	890	130	W1 40.0 > 0.89		W1 40.0
<b>PLATE 550 7/15 ton</b>	1030	820	550	111	W1 65.0 > 1.44 W2 60.0 > 1.53	W1 95.0 > 2.21 W2 80.0 > 1.77	W1 65.0   W1 95.0   W2 60.0   W2 80.0
<b>PLATE 600 7/15 ton</b>	1030	820	600	121	W1 65.0 > 1.32 W2 60.0 > 1.21	W1 95.0 > 2.03 W2 80.0 > 1.62	W1 65.0   W1 95.0   W2 60.0   W2 80.0
<b>PLATE 700 7/15 ton</b>	1030	820	700	141	W1 65.0 > 1.13 W2 60.0 > 1.04	W1 95.0 > 1.74 W2 80.0 > 1.39	W1 65.0   W1 95.0   W2 60.0   W2 80.0
<b>PLATE 890 7/15 ton</b>	1030	820	890	180	W1 65.0 > 0.89 W2 60.0 > 0.82	W1 95.0 > 1.37 W2 80.0 > 0.98	W1 65.0   W1 95.0   W2 60.0   W2 80.0
<b>PLATE 990 7/15 ton</b>	1030	820	990	200	W1 65.0 > 0.80 W2 60.0 > 0.73	W1 95.0 > 1.23 W2 80.0 > 0.89	W1 65.0   W1 95.0   W2 60.0   W2 80.0
<b>PLATE 600 12/20 ton</b>	1110	900	600	160	W2 100.0 > 1.85	W2 120.0 > 2.22	W2 100.0   W2 120.0
<b>PLATE 700 12/20 ton</b>	1110	900	700	185	W2 100.0 > 1.58	W2 120.0 > 1.90	W2 100.0   W2 120.0
<b>PLATE 800 12/20 ton</b>	1110	900	800	205	W2 100.0 > 1.38	W2 120.0 > 1.53	W2 100.0   W2 120.0
<b>PLATE 750 18/40 ton</b>	1270	1060	750	220	W2 150.0 > 1.88	W2 180.0 > 2.26	W2 150.0   W2 180.0
<b>PLATE 850 18/40 ton</b>	1270	1060	850	250	W2 150.0 > 1.66	W2 180.0 > 1.99	W2 150.0   W2 180.0

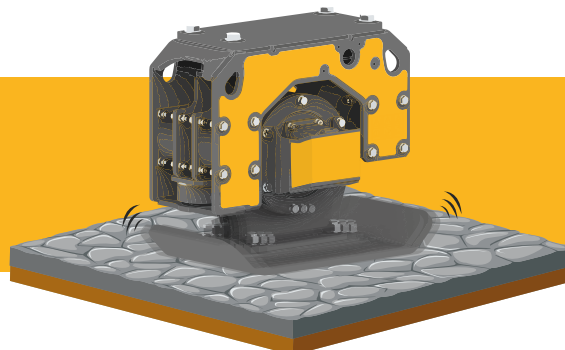





# GRAPPLE

## HOLZGREIFER MIT PFAHLRAMME

- > Entwickelt für das Vibro-Eintreiben und Ziehen von Holz-, Beton- und Stahlpfosten
- > Geeignet für die Eindämmung von Erdbeben, Docks und Böschungen
- > Bau von Weinbergen, Obstplantagen und Zäunen
- > Eine grundlegende Kombination, die in der Gebietserhaltung und Landwirtschaft Verwendung findet

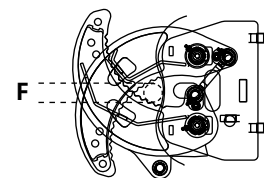
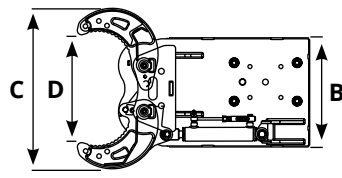
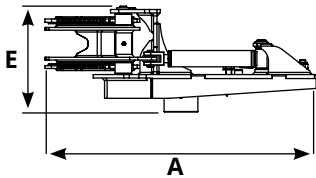
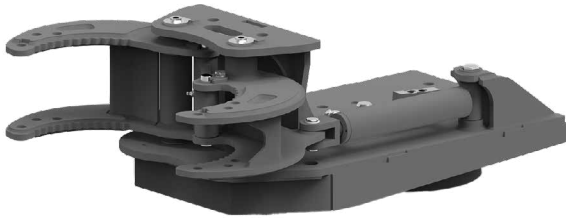

Model	A mm	B mm	C mm	D mm	E mm	F Ø mm	Kg.	Model. PLURY
<b>GRAPPLE 1/4 ton</b>	810	380	560	375	310	35	75	W1 9.0   W1 15.0
<b>GRAPPLE 4/6.5 ton</b>	1090	460	665	425	420	55	159	W1 27.0   W1 40.0
<b>GRAPPLE 7/15 ton</b>	1575	705	870	560	520	140	365	W1 65.0   W2 60.0 W2 80.0
<b>GRAPPLE 8/20 ton</b>	1590	705	870	570	520	140	375	W1 95.0   W2 100.0 W2 120.0
<b>GRAPPLE 18/40 ton</b>	1730	705	870	560	530	140	380	W2 150.0   W2 180.0

Öldurchsatz (L/Min) 10

Max. Gegendruck (BAR) 200



Grapple bietet die Möglichkeit, die maßgeschneiderte Glocke zu montieren, die je nach Bedarf in verschiedenen Durchmessern erhältlich ist. Die Glocke ist im Preis des Greifers enthalten.

Model	A mm	B mm	C mm	Kg	Model. PLURY
<b>BELL 150 - 1/4 ton</b>	150	200	125	15	W1 9.0   W1 15.0
<b>BELL 200 - 1/4 ton</b>	200	250	125	20	W1 9.0   W1 15.0
<b>BELL 150 - 4/6.5 ton</b>	150	200	105	11	W1 27.0   W1 40.0
<b>BELL 200 - 4/6.5 ton</b>	200	250	125	22	W1 27.0   W1 40.0
<b>BELL 250 - 4/6.5 ton</b>	250	300	145	28	W1 27.0   W1 40.0
<b>BELL 150 - 7/40 ton</b>	150	200	105	17	W1 65.0   W1 95.0   W2 60.0   W2 80.0 W2 100.0   W2 120.0   W2 150.0   W2 180.0
<b>BELL 200 - 7/40 ton</b>	200	250	105	20	W1 65.0   W1 95.0   W2 60.0   W2 80.0 W2 100.0   W2 120.0   W2 150.0   W2 180.0
<b>BELL 250 - 7/40 ton</b>	250	300	125	22	W1 65.0   W1 95.0   W2 60.0   W2 80.0 W2 100.0   W2 120.0   W2 150.0   W2 180.0
<b>BELL 300 - 7/40 ton</b>	300	350	180	43	W1 65.0   W1 95.0   W2 60.0   W2 80.0 W2 100.0   W2 120.0   W2 150.0   W2 180.0
<b>BELL 350 - 7/40 ton</b>	350	400	180	50	W1 65.0   W1 95.0   W2 60.0   W2 80.0 W2 100.0   W2 120.0   W2 150.0   W2 180.0



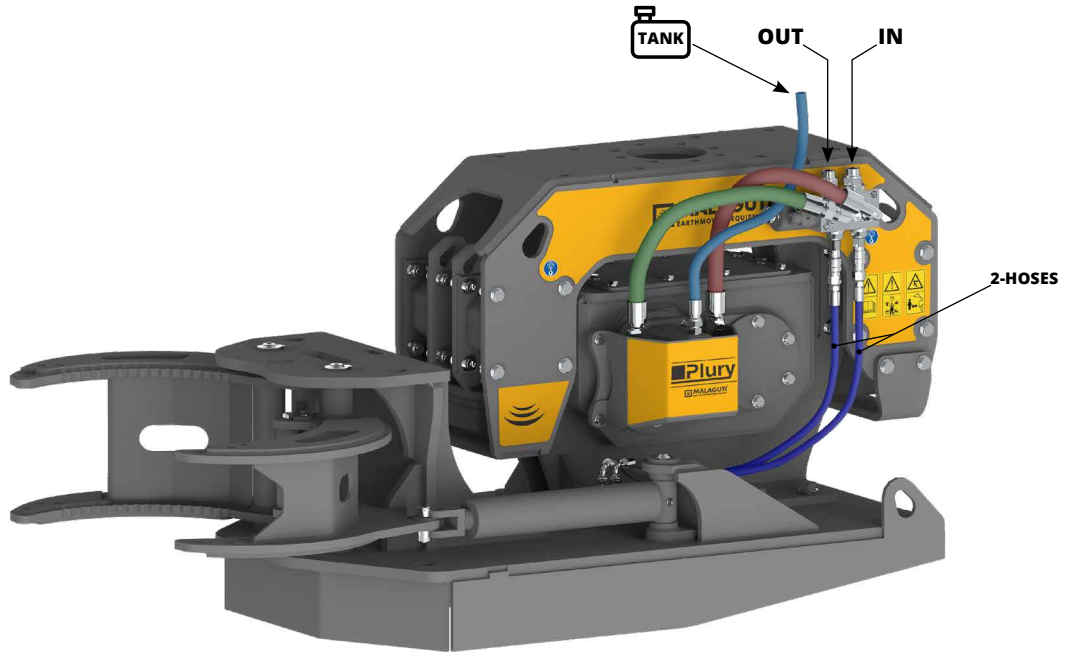

Model	Model. PLURY
<b>2-HOSES VALVE KIT 12Volt - 1</b>	W1 9.0   W1 15.0
<b>2-HOSES VALVE KIT 24Volt - 1</b>	W1 9.0   W1 15.0
<b>2-HOSES VALVE KIT 12Volt - 2</b>	W1 27.0   W1 40.0
<b>2-HOSES VALVE KIT 24Volt - 2</b>	W1 27.0   W1 40.0
<b>2-HOSES VALVE KIT 12Volt - 3</b>	W1 65.0   W1 95.0   W2 60.0   W2 80.0 W2 100.0 W2 120.0   W2 150.0   W2 180.0
<b>2-HOSES VALVE KIT 24Volt - 3</b>	W1 65.0   W1 95.0   W2 60.0   W2 80.0 W2 100.0 W2 120.0   W2 150.0   W2 180.0

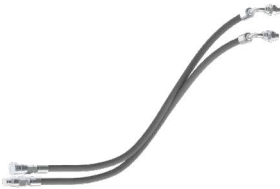

Model	Model. PLURY
<b>2-HOSES GRAPPLE - 1</b>	W1 9.0   W1 15.0
<b>2-HOSES GRAPPLE - 2</b>	W1 27.0   W1 40.0
<b>2-HOSES GRAPPLE - 3</b>	W1 65.0   W1 95.0   W2 60.0   W2 80.0 W2 100.0 W2 120.0   W2 150.0   W2 180.0



Model	Model. PLURY
<b>ELECTRICAL KIT</b>	/

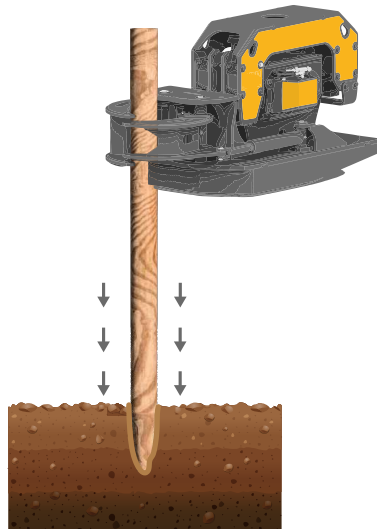

# OPTIONAL GRAPPLE KIT

## OPTIONAL BETON-STAHL

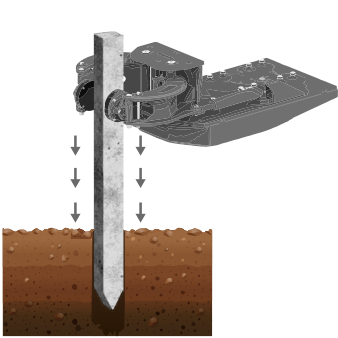
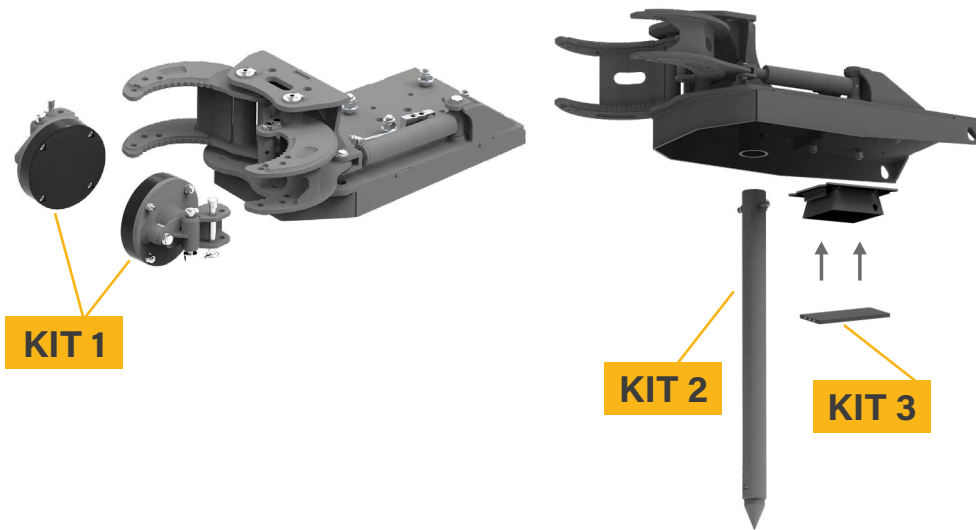

**KIT 1**

- › Zangenzubehör zum Vibro-Eintreiben und Ziehen von Beton- und Stahl Pfählen an alle Greifzange für Holz Tonnagen montierbar

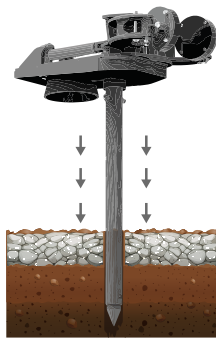

**KIT 2**

- › Vorbohrspitze geeignet zum Vorbohren auf hartem Untergrund
- › Geeignet zum Vibro-Eintreiben von Beton Pfählen

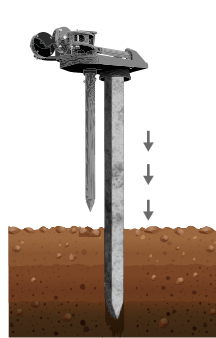

**KIT 3**

- › Zubehör aus stoßdämpfendem Gummi, geeignet zum Vibro-Eintreiben von Beton Pfählen, um Beschädigungen der Pfahl selbst zu vermeiden

## OPTIONALES ZAHNSCHAUFEL

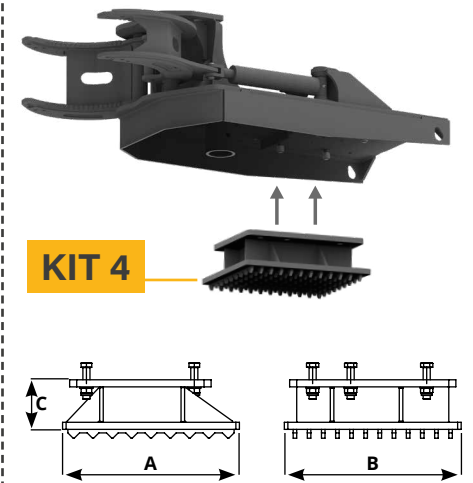

**KIT 4**

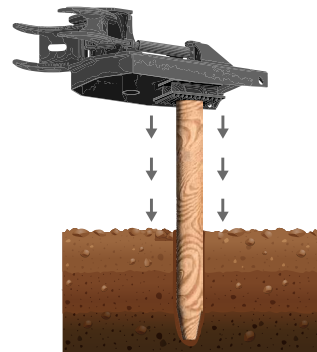
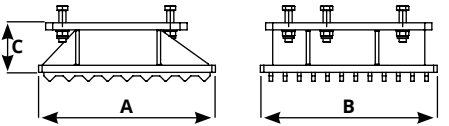

**KIT 4**

- › Zahnschaufel, die anstelle der Glocke für die Vibrationseinbringung von Holzpfählen unterschiedlicher Durchmesser montiert wird

Model	A mm	B mm	C mm	Kg.	Model. GRAPPLE
KIT 1 - 1/4 ton	/	/	/	16	<b>GRAPPLE 1/4 ton</b>
KIT 2 - 1/6.5 ton	/	/	/	22	
KIT 3	Je nach Art der Bell				
KIT 4 - 1/4 ton	335	270	120	23	

Model	A mm	B mm	C mm	Kg.	Model. GRAPPLE
KIT 1 - 4/6.5 ton	/	/	/	20	<b>GRAPPLE 4/6.5 ton</b>
KIT 2 - 1/6.5 ton	/	/	/	22	
KIT 3	Je nach Art der Bell				
KIT 4 - 4/6.5 ton	350	400	130	44	

Model	A mm	B mm	C mm	Kg.	Model. GRAPPLE
KIT 1 - 7/40 ton	/	/	/	24	<b>GRAPPLE 7/15 ton</b>
KIT 2 - 7/20 ton	/	/	/	27	
KIT 3	Je nach Art der Bell				<b>GRAPPLE 8/20 ton</b>
KIT 4 - 7/20 ton	500	500	165	90	

Model	A mm	B mm	C mm	Kg.	Model. GRAPPLE
KIT 1 - 7/40 ton	/	/	/	24	<b>GRAPPLE 18/40 ton</b>
KIT 2 - 18/40 ton	/	/	/	43	
KIT 3	Je nach Art der Bell				
KIT 4 - 18/40 ton	540	500	175	100	





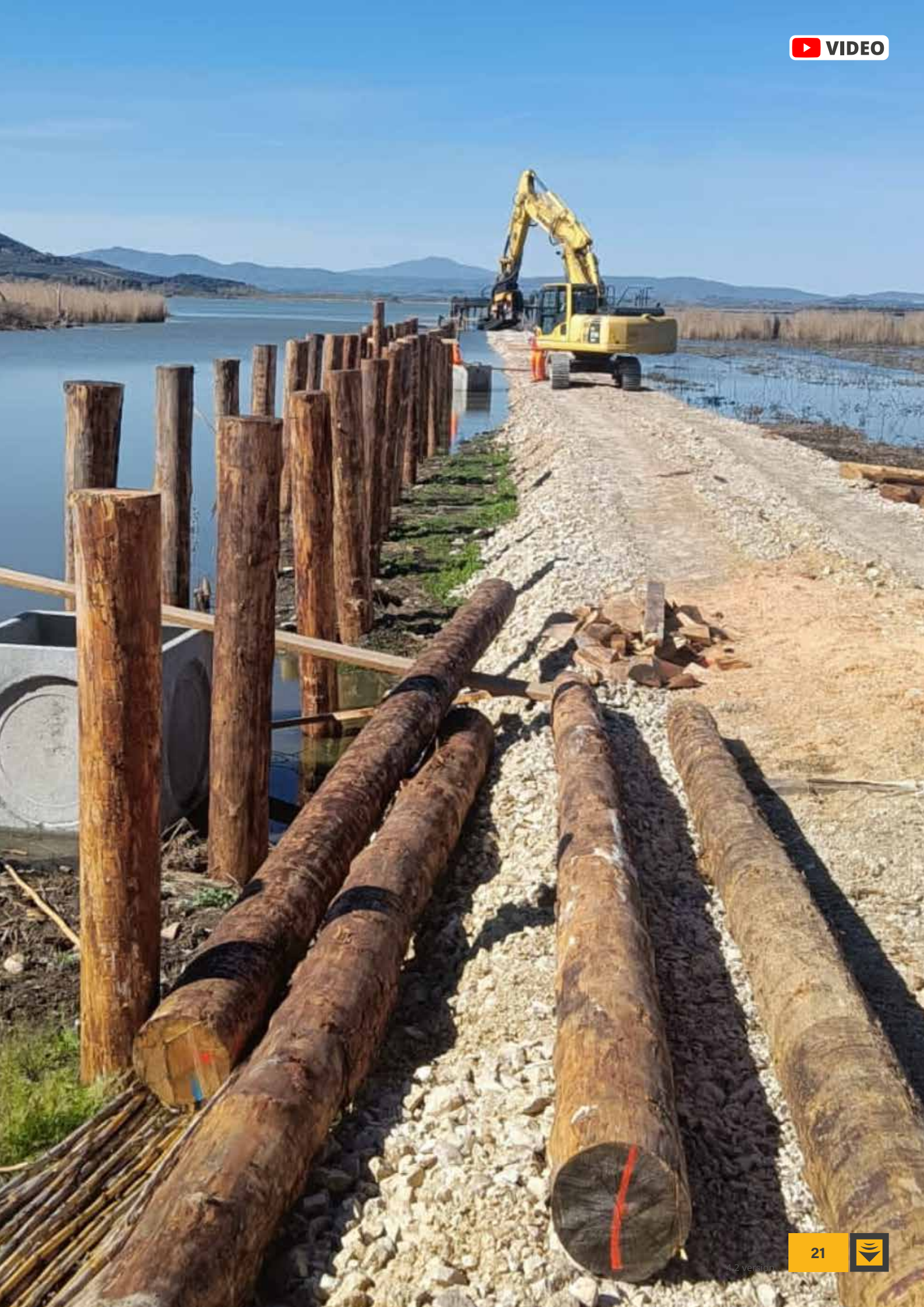



# BELL

## ZENTRIEREN VON PFÄHLEN

- › Entwickelt für das Vibro-Eintreiben von Holz-, Beton- und Stahlpfosten

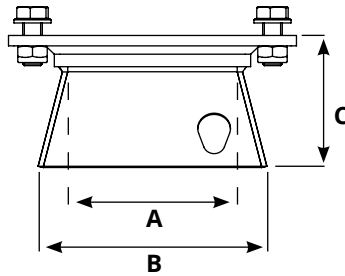

Model	A mm	B mm	C mm	Kg.	Model. PLURY
<b>BELL 150 - 1/4 ton</b>	150	200	125	12	W1 9.0   W1 15.0
<b>BELL 200 - 1/4 ton</b>	200	250	125	17	W1 9.0   W1 15.0
<b>BELL 150 - 4/6.5 ton</b>	150	200	105	11	W1 27.0   W1 40.0
<b>BELL 200 - 4/6.5 ton</b>	200	250	125	20	W1 27.0   W1 40.0
<b>BELL 250 - 4/6.5 ton</b>	250	300	145	24	W1 27.0   W1 40.0
<b>BELL 150 - 7/40 ton</b>	150	200	105	17	W1 65.0   W1 95.0   W2 60.0   W2 80.0 W2 100.0   W2 120.0   W2 150.0   W2 180.0
<b>BELL 200 - 7/40 ton</b>	200	250	105	20	W1 65.0   W1 95.0   W2 60.0   W2 80.0 W2 100.0   W2 120.0   W2 150.0   W2 180.0
<b>BELL 250 - 7/40 ton</b>	250	300	125	22	W1 65.0   W1 95.0   W2 60.0   W2 80.0 W2 100.0   W2 120.0   W2 150.0   W2 180.0
<b>BELL 300 - 7/40 ton</b>	300	350	180	37	W1 65.0   W1 95.0   W2 60.0   W2 80.0 W2 100.0   W2 120.0   W2 150.0   W2 180.0
<b>BELL 350 - 7/40 ton</b>	350	400	180	43	W1 65.0   W1 95.0   W2 60.0   W2 80.0 W2 100.0   W2 120.0   W2 150.0   W2 180.0



### Model

**KIT 3 - 150**

**KIT 3 - 200**

**KIT 3 - 250**

**KIT 3 - 300**

**KIT 3 - 350**

- › Stoßdämpfendes Gummizubehör, das zum Rütteln von Betonpfosten geeignet ist und eine Beschädigung des Pfostens selbst vermeidet

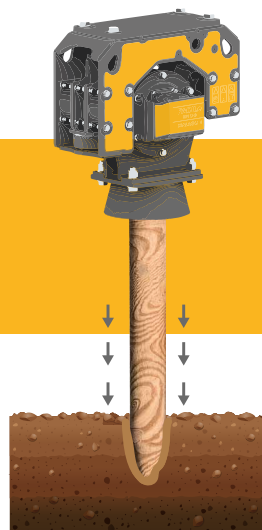

# T-DRILLING + ADAPTER

## VORBOHRER

- > Vorbohrer geeignet zum Vorbohren auf hartem Untergrund
- > Geeignet zum Vibro-Eintreiben von Beton Pfählen

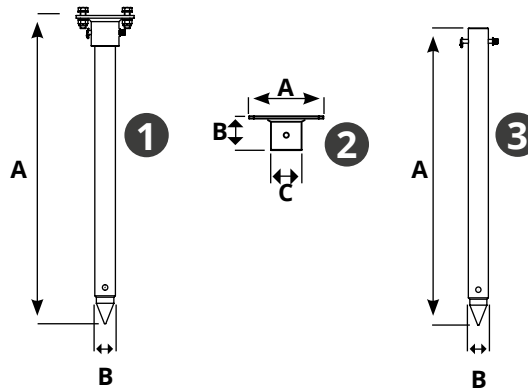

1

Model	A mm	B mm	Kg.	Model. PLURY	€
<b>T-DRILLING + ADAPTER 1/6.5 ton</b>	1110	76	29	W1 9.0   W1 15.0   W1 27.0   W1 40.0	416,00 €
<b>T-DRILLING + ADAPTER 7/20 ton</b>	1110	89	43	W1 65.0   W1 95.0   W2 60.0   W2 80.0 W2 100.0   W2 120.0	587,00 €
<b>T-DRILLING + ADAPTER 18/40 ton</b>	1130	101.6	51	W2 150.0   W2 180.0	739,00 €

2

Model	A mm	B mm	C mm Ø int.	Kg.	Model. PLURY	€
<b>T-DRILLING ADAPTER 1/6.5 ton</b>	260	112	78	7	W1 9.0   W1 15.0   W1 27.0   W1 40.0	121,00 €
<b>T-DRILLING ADAPTER 7/20 ton</b>	265	145	90.5	16	W1 65.0   W1 95.0   W2 60.0   W2 80.0 W2 100.0   W2 120.0	225,00 €
<b>T-DRILLING ADAPTER 18/40 ton</b>	265	155	102.5	19	W2 150.0   W2 180.0	282,00 €

3

Model	A mm	B mm	Kg.	Model. PLURY	€
<b>T-DRILLING 1/12 ton</b>	1095	76	22	W1 9.0   W1 15.0   W1 27.0   W1 40.0	295,00 €
<b>T-DRILLING 8/25 ton</b>	1095	89	27	W1 65.0   W1 95.0   W2 60.0   W2 80.0 W2 100.0   W2 120.0	362,00 €
<b>T-DRILLING 18/40 ton</b>	1095	101.6	32	W2 150.0   W2 180.0	457,00 €

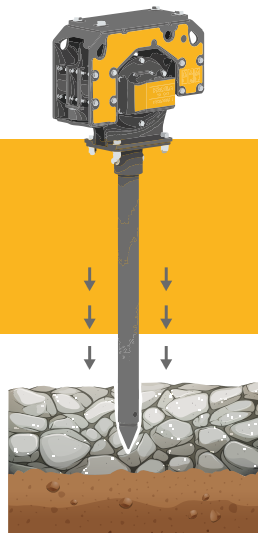



# T-PLATE

## SCHMALE SOHLE - EINZELN SCHLITTEN

- > Ideal für Verdichtungsarbeiten in schmalen Gräben
- > Ermöglicht der Sohle, tief zu reichen
- > Besonders geeignet für die Erdung von Glasfaser- und unterirdischen Versorgungsleitungen

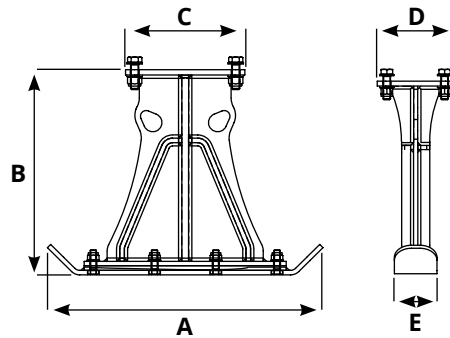

Model	A mm	B mm	C mm	D mm	E mm	Kg.	Model. PLURY
<b>T-PLATE 100 1/4 ton</b>	600	450	260	180	100	31	W1 9.0   W1 15.0
<b>T-PLATE 150 1/4 ton</b>	600	450	260	180	150	34	W1 9.0   W1 15.0
<b>T-PLATE 120 4/6.5 ton</b>	800	550	420	250	120	65	W1 27.0   W1 40.0
<b>T-PLATE 150 4/6.5 ton</b>	800	550	420	250	150	70	W1 27.0   W1 40.0
<b>T-PLATE 200 4/6.5 ton</b>	800	550	420	250	200	75	W1 27.0   W1 40.0
<b>T-PLATE 135 7/40 ton</b>	1050	700	540	360	135	130	W1 65.0   W1 95.0   W2 60.0 W2 80.0   W2 100.0   W2 120.0 W2 150.0   W2 180.0
<b>T-PLATE 200 7/40 ton</b>	1050	700	540	360	200	150	W1 65.0   W1 95.0   W2 60.0 W2 80.0   W2 100.0   W2 120.0 W2 150.0   W2 180.0

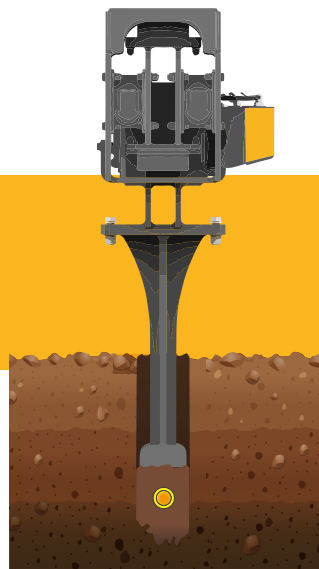



# TWIN PLATE

## SCHMALE SOHLE - DOPPELSCHLITTEN

- > Ideal für Verdichtungsarbeiten in schmalen Gräben
- > Ermöglicht der Sohle, tief zu reichen
- > Besonders geeignet für die Erdung von Glasfaser- und unterirdischen Versorgungsleitungen

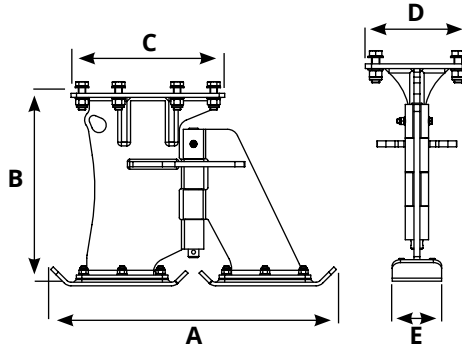

Model	A mm	B mm	C mm	D mm	E mm	Kg.	Model. PLURY
<b>TWIN PLATE 100 1/4 ton</b>	600	480	260	180	100	27	W1 9.0   W1 15.0
<b>TWIN PLATE 150 1/4 ton</b>	600	480	260	180	150	35	W1 9.0   W1 15.0
<b>TWIN PLATE 120 4/6.5 ton</b>	780	520	420	250	120	56	W1 27.0   W1 40.0
<b>TWIN PLATE 150 4/6.5 ton</b>	780	520	420	250	150	64	W1 27.0   W1 40.0
<b>TWIN PLATE 200 4/6.5 ton</b>	780	520	420	250	200	70	W1 27.0   W1 40.0
<b>TWIN PLATE 135 7/40 ton</b>	1100	600	540	360	135	120	W1 65.0   W1 95.0   W2 60.0 W2 80.0   W2 100.0   W2 120.0 W2 150.0   W2 180.0
<b>TWIN PLATE 200 7/40 ton</b>	1100	600	540	360	200	140	W1 65.0   W1 95.0   W2 60.0 W2 80.0   W2 100.0   W2 120.0 W2 150.0   W2 180.0

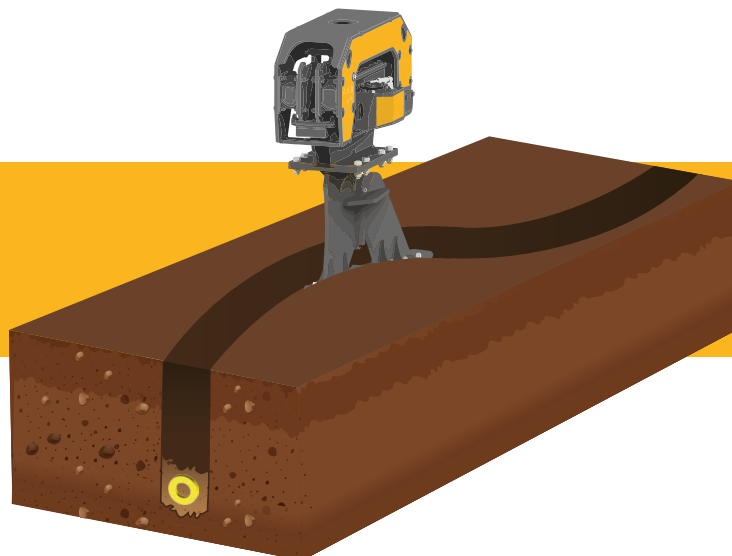

# ONE WHEEL

## EINZELRAD

- > Ideal für Verdichtungsarbeiten in schmalen Gräben
- > Es ermöglicht dem Rad, tief zu reichen
- > Besonders geeignet für die Erdung von Glasfaser- und unterirdischen Versorgungsleitungen

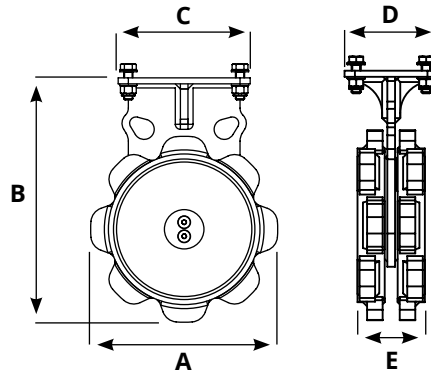

Model	A mm	B mm	C mm	D mm	E mm	Kg.	Model. PLURY
<b>ONE WHEEL 130 1/4.5 ton</b>	370	485	260	180	130	46	W1 9.0   W1 15.0
<b>ONE WHEEL 200 1/4.5 ton</b>	370	485	260	180	200	58	W1 9.0   W1 15.0
<b>ONE WHEEL 200 4/12 ton</b>	480	600	420	250	200	95	W1 27.0   W1 40.0
<b>ONE WHEEL 300 4/12 ton</b>	480	600	420	250	300	110	W1 27.0   W1 40.0
<b>ONE WHEEL 270 8/40 ton</b>	710	830	540	360	270	212	W1 65.0   W1 95.0   W2 60.0 W2 80.0   W2 100.0   W2 120.0 W2 150.0   W2 180.0
<b>ONE WHEEL 350 8/40 ton</b>	710	830	540	360	350	243	W1 65.0   W1 95.0   W2 60.0 W2 80.0   W2 100.0   W2 120.0 W2 150.0   W2 180.0

- > Mittels der MASCHINENANSCHLÜSSEN kann das Rad ohne Drehwerk direkt an der Arbeitsmaschine montiert werden

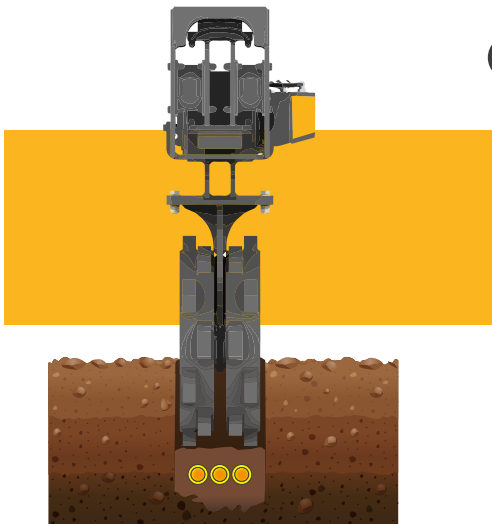
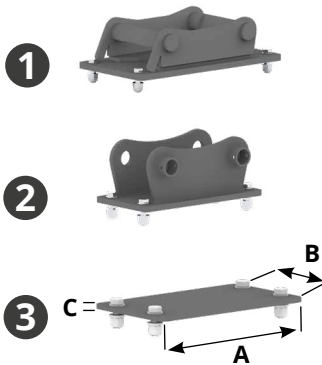

Model	A mm	B mm	C mm	Kg.
<b>ADAPTER FOR QUICK COUPLING 1/4.5 ton</b>	/	/	/	/
<b>ADAPTER FOR QUICK COUPLING 4/12 ton</b>	/	/	/	/
<b>ADAPTER FOR QUICK COUPLING 8/14 ton</b>	/	/	/	/
<b>ADAPTER FOR QUICK COUPLING 12/25 ton</b>	/	/	/	/
<b>ADAPTER FOR QUICK COUPLING 18/40 ton</b>	/	/	/	/
<b>FIXED COUPLING MACHINE 1/4.5 ton</b>	/	/	/	/
<b>FIXED COUPLING MACHINE 4/12 ton</b>	/	/	/	/
<b>FIXED COUPLING MACHINE 8/14 ton</b>	/	/	/	/
<b>FIXED COUPLING MACHINE 12/25 ton</b>	/	/	/	/
<b>FIXED COUPLING MACHINE 18/40 ton</b>	/	/	/	/
<b>BOLTED PLATE MACHINE COUPLING 1/2 ton</b>	390	195	10	7
<b>BOLTED PLATE MACHINE COUPLING 1/4.5 ton</b>	410	235	10	8.5
<b>BOLTED PLATE MACHINE COUPLING 4/12 ton</b>	470	280	15	16.5
<b>BOLTED PLATE MACHINE COUPLING 8/14 ton</b>	640	340	15	29
<b>BOLTED PLATE MACHINE COUPLING 12/25 ton</b>	710	400	20	48
<b>BOLTED PLATE MACHINE COUPLING 18/40 ton</b>	920	450	20	70





# TWIN WHEEL

## DOPPELRAD

- › Ideal für Verdichtungsarbeiten in schmalen Gräben
- › Es ermöglicht dem Rad, tief zu reichen
- › Besonders geeignet für die Erdung von Glasfaser- und unterirdischen Versorgungsleitungen

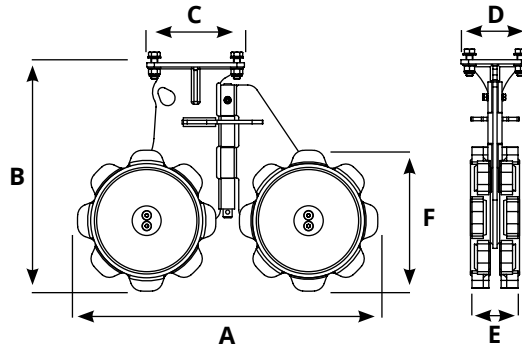

Model	A mm	B mm	C mm	D mm	E mm	F mm	Kg.	Model. PLURY
TWIN WHEEL 130 1/4.5 ton	805	596	260	370	130	370	86	W1 9.0   W1 15.0
TWIN WHEEL 200 1/4.5 ton	805	596	260	370	200	370	115	W1 9.0   W1 15.0
TWIN WHEEL 200 4/12 ton	1065	715	420	250	200	480	185	W1 27.0   W1 40.0
TWIN WHEEL 300 4/12 ton	1065	715	420	250	300	480	230	W1 27.0   W1 40.0
TWIN WHEEL 270 8/40 ton	1540	890	540	360	270	710	408	W1 65.0   W1 95.0   W2 60.0 W2 80.0   W2 100.0   W2 120.0 W2 150.0   W2 180.0
TWIN WHEEL 3508/40 ton	1540	890	540	360	350	710	442	W1 65.0   W1 95.0   W2 60.0 W2 80.0   W2 100.0   W2 120.0 W2 150.0   W2 180.0

- › Mittels der MASCHINENANSCHLÜSSEN kann das Rad ohne Drehwerk direkt an der Arbeitsmaschine montiert werden

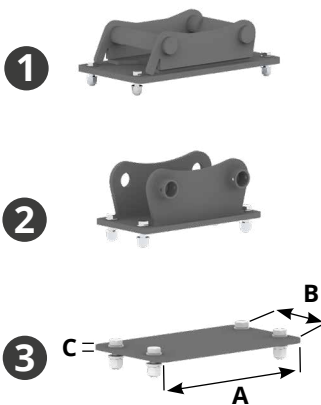

	Model	A mm	B mm	C mm	Kg.
	ADAPTER FOR QUICK COUPLING 1/4.5 ton	/	/	/	/
	ADAPTER FOR QUICK COUPLING 4/12 ton	/	/	/	/
1	ADAPTER FOR QUICK COUPLING 8/14 ton	/	/	/	/
	ADAPTER FOR QUICK COUPLING 12/25 ton	/	/	/	/
	ADAPTER FOR QUICK COUPLING 18/40 ton	/	/	/	/
	FIXED COUPLING MACHINE 1/4.5 ton	/	/	/	/
	FIXED COUPLING MACHINE 4/12 ton	/	/	/	/
2	FIXED COUPLING MACHINE 8/14 ton	/	/	/	/
	FIXED COUPLING MACHINE 12/25 ton	/	/	/	/
	FIXED COUPLING MACHINE 18/40 ton	/	/	/	/
	BOLTED PLATE MACHINE COUPLING 1/2 ton	390	195	10	7
	BOLTED PLATE MACHINE COUPLING 1/4.5 ton	410	235	10	8.5
3	BOLTED PLATE MACHINE COUPLING 4/12 ton	470	280	15	16.5
	BOLTED PLATE MACHINE COUPLING 8/14 ton	640	340	15	29
	BOLTED PLATE MACHINE COUPLING 12/25 ton	710	400	20	48
	BOLTED PLATE MACHINE COUPLING 18/40 ton	920	450	20	70

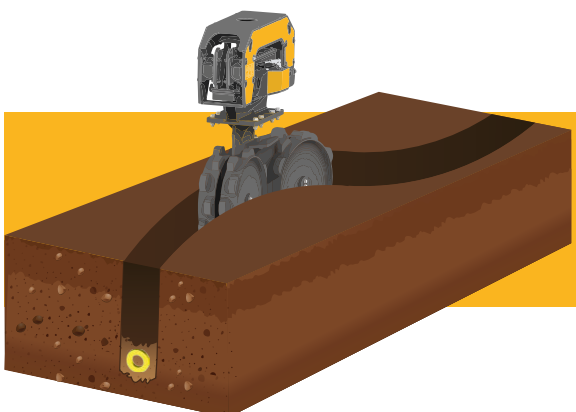

# STORM WHEEL

## VERDICHTERRAD

- > Ideal für Verdichtungsarbeiten
- > Ideal zum Verdichten von Böden oder Auffüllmaterial
- > Die Ausstattung sorgt für einen garantiert homogenen, soliden und dauerhaft festen Untergrund

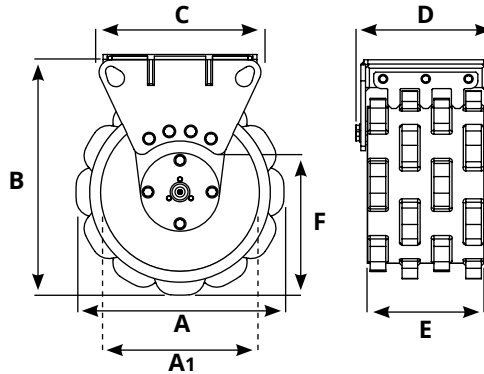

Model	A mm	A1 mm	B mm	C mm	D mm	E mm	F mm	Kg.	Model. PLURY
STORM 40 L200 1/4.5 ton	505	400	595	420	260	200	341	115	W1 9.0   W1 15.0
STORM 40 L300 1/4.5 ton	505	400	595	360	360	300	341	140	W1 9.0   W1 15.0
STORM 40 L400 1/4.5 ton	505	400	595	280	460	400	341	165	W1 9.0   W1 15.0
STORM 40 L500 1/4.5 ton	505	400	595	280	560	500	341	191	W1 9.0   W1 15.0
STORM 50 L300 4/12 ton	615	500	700	430	370	300	393	206	W1 27.0   W1 40.0
STORM 50 L400 4/12 ton	615	500	700	430	470	400	393	235	W1 27.0   W1 40.0
STORM 50 L500 4/12 ton	615	500	700	430	570	500	393	272	W1 27.0   W1 40.0
STORM 50 L600 4/12 ton	615	500	700	430	670	600	393	302	W1 27.0   W1 40.0
STORM 65 L400 8/40 ton	790	650	895	540	485	400	527	363	W1 65.0   W1 95.0   W2 60.0 W2 80.0   W2 100.0   W2 120.0 W2 150.0   W2 180.0
STORM 65 L600 8/40 ton	790	650	895	540	685	600	527	458	
STORM 65 L800 8/40 ton	790	650	895	540	885	800	527	555	
STORM 90 L600 18/40 ton	1045	900	1170	600	700	600	728	662	/
STORM 90 L800 18/40 ton	1045	900	1170	600	900	800	728	775	/
STORM 90 L1000 18/40 ton	1045	900	1170	600	1100	1000	728	895	/

- > Mittels der MASCHINENANSCHLÜSSEN kann das Rad ohne Drehwerk direkt an der Arbeitsmaschine montiert werden

	Model	A mm	B mm	C mm	Kg.
	ADAPTER FOR QUICK COUPLING 1/4.5 ton	/	/	/	/
	ADAPTER FOR QUICK COUPLING 4/12 ton	/	/	/	/
1	ADAPTER FOR QUICK COUPLING 8/14 ton	/	/	/	/
	ADAPTER FOR QUICK COUPLING 12/25 ton	/	/	/	/
	ADAPTER FOR QUICK COUPLING 18/40 ton	/	/	/	/
	FIXED COUPLING MACHINE 1/4.5 ton	/	/	/	/
	FIXED COUPLING MACHINE 4/12 ton	/	/	/	/
2	FIXED COUPLING MACHINE 8/14 ton	/	/	/	/
	FIXED COUPLING MACHINE 12/25 ton	/	/	/	/
	FIXED COUPLING MACHINE 18/40 ton	/	/	/	/
	BOLTED PLATE MACHINE COUPLING 1/2 ton	390	195	10	7
	BOLTED PLATE MACHINE COUPLING 1/4.5 ton	410	235	10	8.5
3	BOLTED PLATE MACHINE COUPLING 4/12 ton	470	280	15	16.5
	BOLTED PLATE MACHINE COUPLING 8/14 ton	640	340	15	29
	BOLTED PLATE MACHINE COUPLING 12/25 ton	710	400	20	48
	BOLTED PLATE MACHINE COUPLING 18/40 ton	920	450	20	70

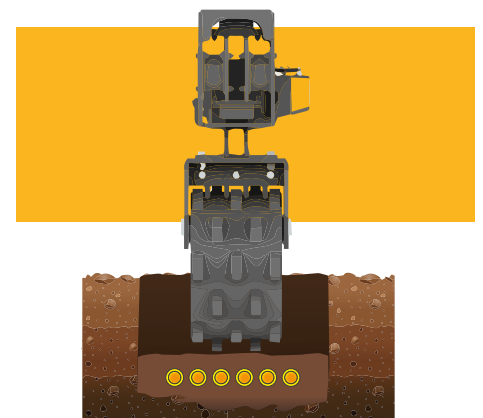
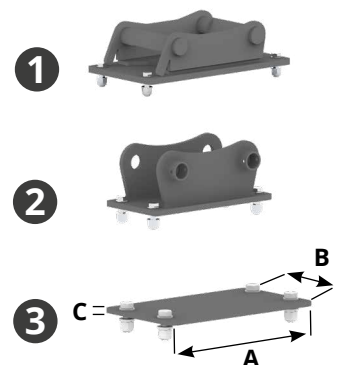





# ASPHALT CUTTER

## ASPHALTSCHNEIDER

- › Ideal zum Schneiden von Asphalt vor dem Ausheben eines Grabens

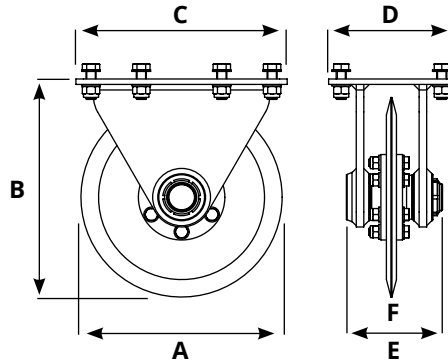

Model	A mm	B mm	C mm	D mm	E mm	F mm	Kg.	Cut. depth mm	Model. PLURY
ASPHALT CUTTER 400 4/12 ton	400	440	420	250	115	12	56	120	W1 27.0   W1 40.0
ASPHALT CUTTER 500 8/40 ton	500	540	540	360	140	12	107	170	W1 65.0   W1 95.0   W2 60.0 W2 80.0   W2 100.0   W2 120.0 W2 150.0   W2 180.0

- › Mittels der MASCHINENANSCHLÜSSEN kann das Rad ohne Drehwerk direkt an der Arbeitsmaschine montiert werden

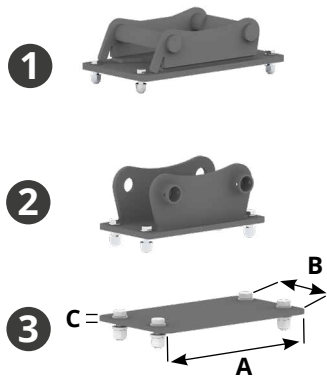

	Model	A mm	B mm	C mm	Kg.
1	ADAPTER FOR QUICK COUPLING 4/12 ton	/	/	/	/
1	ADAPTER FOR QUICK COUPLING 8/14 ton	/	/	/	/
	ADAPTER FOR QUICK COUPLING 12/25 ton	/	/	/	/
	ADAPTER FOR QUICK COUPLING 18/40 ton	/	/	/	/
	FIXED COUPLING MACHINE 4/12 ton	/	/	/	/
2	FIXED COUPLING MACHINE 8/14 ton	/	/	/	/
	FIXED COUPLING MACHINE 12/25 ton	/	/	/	/
	FIXED COUPLING MACHINE 18/40 ton	/	/	/	/
	BOLTED PLATE MACHINE COUPLING 4/12 ton	470	280	15	16.5
3	BOLTED PLATE MACHINE COUPLING 8/14 ton	640	340	15	29
	BOLTED PLATE MACHINE COUPLING 12/25 ton	710	400	20	48
	BOLTED PLATE MACHINE COUPLING 18/40 ton	920	450	20	70

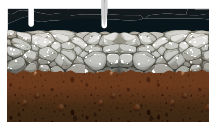
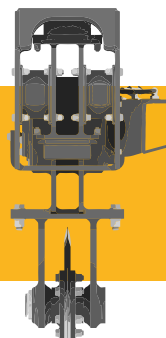



# SHEET PILE CLAMP

## ZANGE FÜR SPUNDWÄNDEN

- › Zange geeignet zum Vibro-Eintreiben und Ziehen von Spundwänden in verschiedenen Geländearten
- › Ideal zum Rütteln von in Beton eingetauchten Stahlkörben

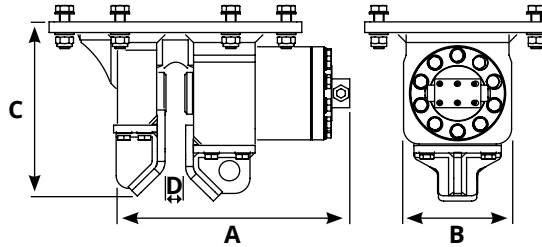

Model	A mm	B mm	C mm	D mm	Press. Bar	Force max press	Kg.	Model. PLURY
<b>SHEET PILE CLAMP 25 GRIP</b>	455	210	350	32	200	23 Ton	170	W2 60.0   W2 80.0
					250	28 Ton		W2 100.0   W2 120.0 W2 150.0   W2 180.0

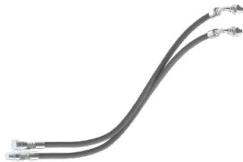

Model	Model. PLURY
<b>2-HOSES VALVE KIT 12Volt - 3</b>	W2 60.0   W2 80.0   W2 100.0   W2 120.0 W2 150.0   W2 180.0
<b>2-HOSES VALVE KIT 24Volt - 3</b>	W2 60.0   W2 80.0   W2 100.0   W2 120.0 W2 150.0   W2 180.0

Model	Model. PLURY
<b>2-HOSES SHEET PILE CLAMP</b>	W2 60.0   W2 80.0   W2 100.0   W2 120.0 W2 150.0   W2 180.0

Model	Model. PLURY
<b>ELECTRICAL KIT</b>	/

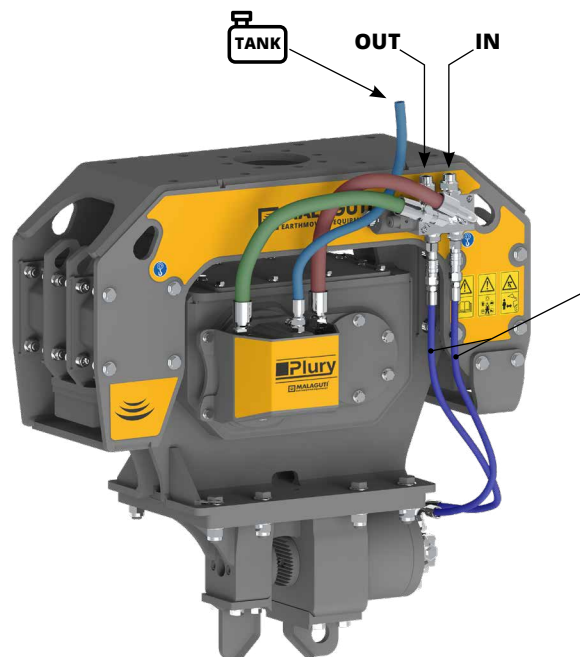
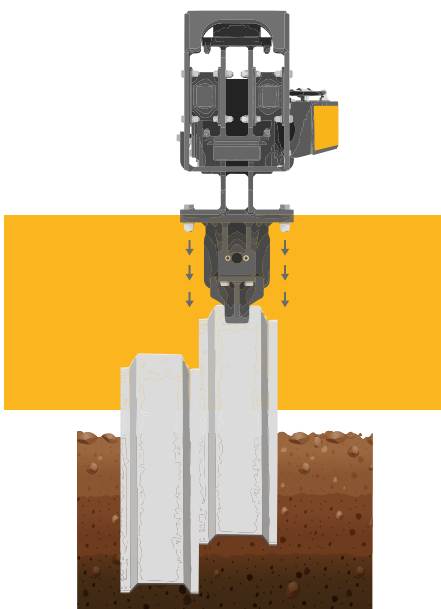



# H-BEAM CLAMP

## KLAMMER FÜR H-TRÄGER

- › Klammer für das vibro Rammen und Herausziehen von H-Trägern in verschiedenen Bodenarten

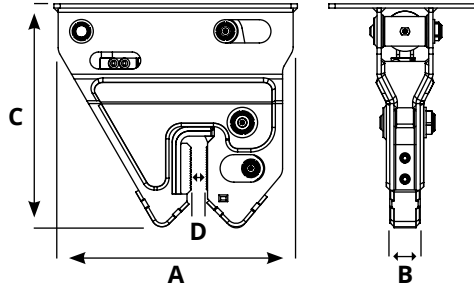

Model	A mm	B mm	C mm	D mm	Press. Bar	Force max press	Kg.	Model. PLURY
<b>H-BEAM CLAMP 20 GRIP</b>	580	72	430	35	200	20 Ton	95	W2 60.0   W2 80.0
					250	23 Ton		W2 100.0   W2 120.0 W2 150.0   W2 180.0



Model	Model. PLURY
<b>2-HOSES VALVE KIT 12Volt - 3</b>	W2 60.0   W2 80.0   W2 100.0   W2 120.0 W2 150.0   W2 180.0
<b>2-HOSES VALVE KIT 24Volt - 3</b>	W2 60.0   W2 80.0   W2 100.0   W2 120.0 W2 150.0   W2 180.0



Model	Model. PLURY
<b>2-HOSES SHEET PILE CLAMP</b>	W2 60.0   W2 80.0   W2 100.0   W2 120.0 W2 150.0   W2 180.0
<b>ELECTRICAL KIT</b>	/

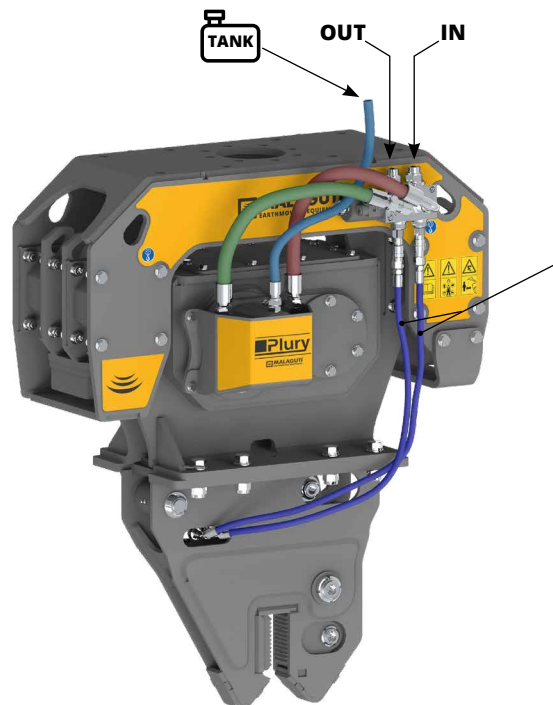
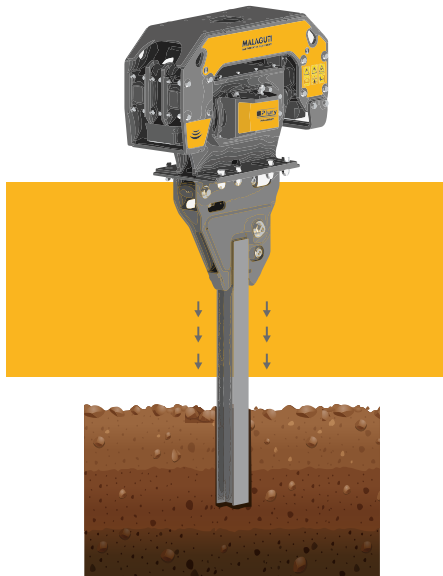



# PLURY KN

## DOPPEL VERDICHTERPLATTE ZUM FRONTANBAU

- › Mit dem Verdichterplatte zum Frontanbau können Sie eine große Fläche schneller verdichten
- › Geeignet zum Verdichten von Plätzen, Radwegen etc.

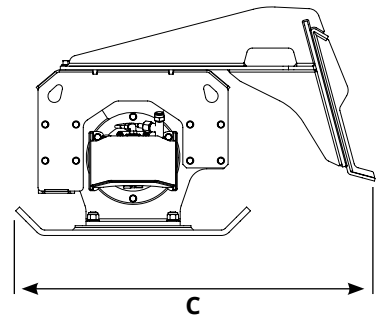
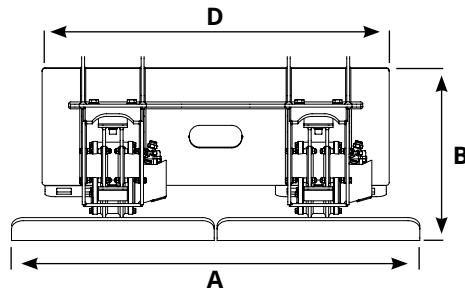

Model	A mm	B mm	C mm	D mm	Kg.	Model. PLURY
PLURY KN 9+9 120	1200	525	990	1190	400	W1 9.0
PLURY KN 9+9 140	1400	525	990	1190	420	W1 9.0
PLURY KN 15+15 140	1400	630	1000	1190	485	W1 15.0
PLURY KN 15+15 160	1600	630	1000	1190	505	W1 15.0
PLURY KN 27+27 160	1600	730	1150	1190	790	W1 27.0
PLURY KN 27+27 180	1800	730	1150	1190	820	W1 27.0
PLURY KN 40+40 180	1800	730	1150	1190	825	W1 40.0
PLURY KN 40+40 200	2000	730	1150	1190	885	W1 40.0
PLURY KN 65+65 200	2000	840	1250	1190	1290	W1 65.0
PLURY KN 65+65 220	2200	840	1250	1190	1330	W1 65.0

### Model

COUPLING TO LOADER  
supplément pour PALE







# FRONT-MOUNTED ATTACHMENT

## EINZELNE FRONTBEFESTIGUNG FÜR PLURY

- › Durch den Einsatz des Plury-Frontanbau ist es möglich, den Drehwerk auf Arbeitsmaschinen wie Kompaktlader, Mini-Kompaktlader, Mini-Radlader einzusetzen

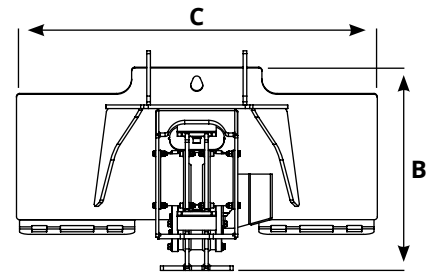
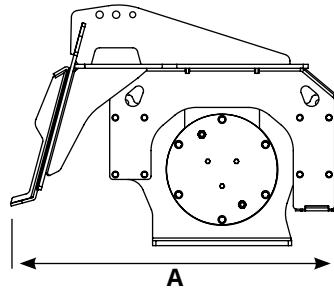

Model	A mm	B mm	C mm	Kg.	Model. PLURY
FRONT-MOUNTED ATTACHMENT PLURY 1.5 - 4.5 ton	796	566	1190	90	W1 15.0
FRONT-MOUNTED ATTACHMENT PLURY 4 - 12 ton	847	673	1190	115	W1 27.0   W1 40.0
FRONT-MOUNTED ATTACHMENT PLURY 8 - 16 ton	1005	805	1190	150	W1 65.0   W1 95.0 W2 60.0   W2 80.0

Model  
COUPLING TO LOADER  
supplément pour PALE

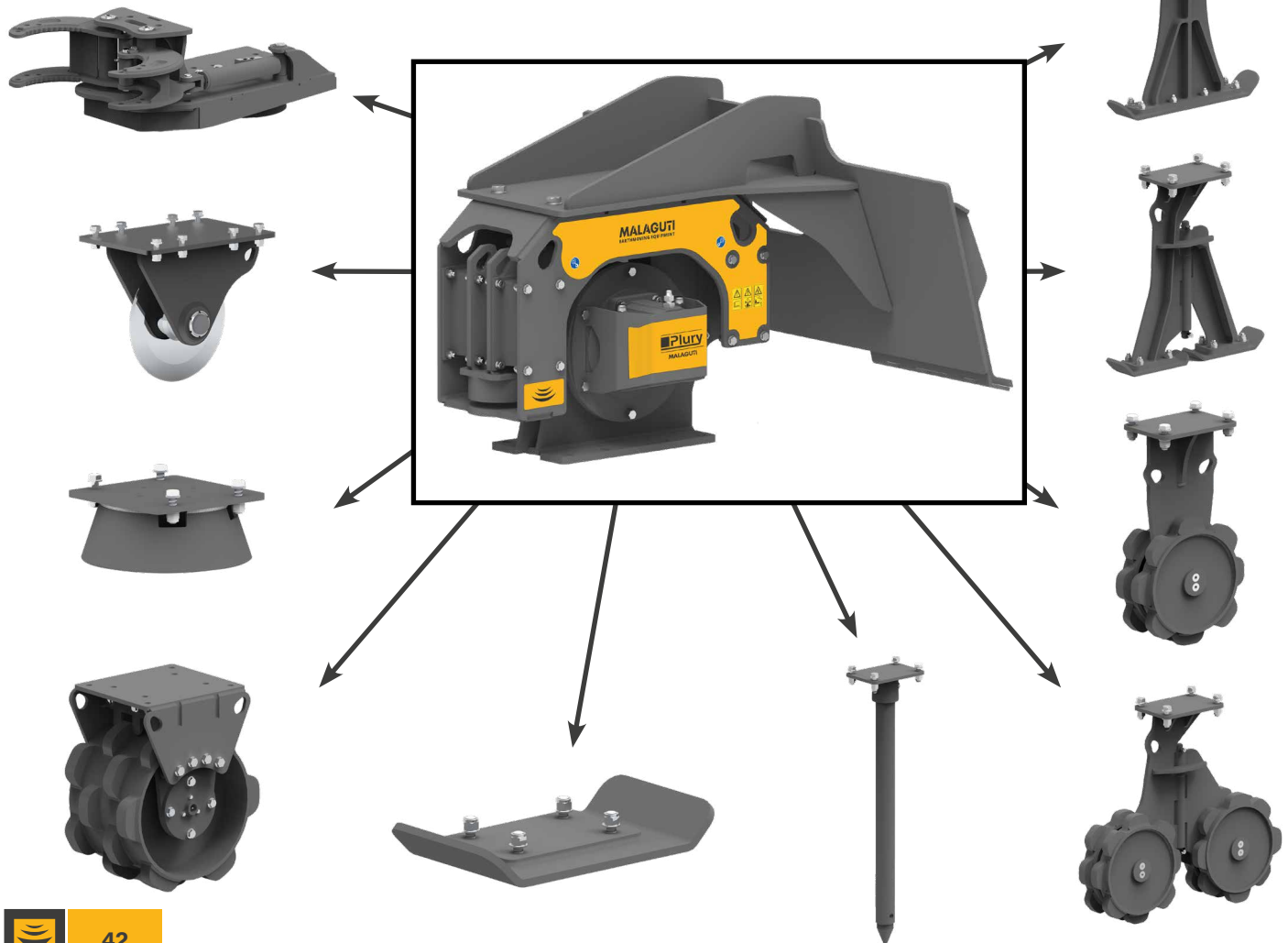

# GENERAL SALES INFORMATION

THE FOLLOWING GENERAL SALES CONDITIONS ARE BINDING AND FORM AN INTEGRAL PART OF THE CONTRACTS CONCLUDED BETWEEN THE SELLER AND THE BUYER FOR THE SUPPLY OF THE SELLER'S PRODUCTS (THE "PRODUCTS").

THESE SALES CONDITIONS APPLY TO ALL TRANSACTIONS CONCLUDED WITH THE SELLER AND THE BUYER WITHOUT THE NEED FOR EXPLICIT REFERENCE TO THEM OR A SPECIFIC AGREEMENT IN THIS REGARD AT THE CONCLUSION OF EACH INDIVIDUAL TRANSACTION. ANY DIFFERENT CONDITION OR TERM WILL APPLY ONLY IF CONFIRMED IN WRITING BY THE SELLER.

THE SELLER RESERVES THE RIGHT TO MODIFY, SUPPLEMENT, OR AMEND THE GENERAL SALES CONDITIONS, ATTACHING SUCH VARIATIONS TO OFFERS OR ANY WRITTEN CORRESPONDENCE SENT TO THE BUYER.

## OFFERS AND ORDERS

The Seller's offers are not binding, especially concerning quantity, prices, and delivery terms. Orders placed by the Buyer are not considered accepted until they are confirmed in writing by the Seller. The Buyer has the option to modify and/or cancel the order within 24 hours of receipt, as expressly stated in the order confirmation. Orders and/or order modifications made verbally or over the phone must be confirmed in writing by the Buyer; otherwise, the Seller assumes no responsibility for any errors or misunderstandings.

## PRICES AND PAYMENT TERMS

The price of the products and spare parts, if not indicated in the order confirmation, is the one established in the 4.0 price list in effect at the time of the order. Product prices do not include VAT, which must be paid at the time of delivery or in accordance with the specific provisions indicated on the invoice. Taxes, duties, shipping, insurance, after-sales service are not included in the prices unless separately quoted. In case of delayed or non-payment within the agreed terms, the Seller has the right to apply late payment interest, in addition to seeking compensation for any other damages suffered, as well as suspend and/or cancel further deliveries and demand immediate payment of the outstanding amount. The Parties hereby agree that in the event of disputes between them relating to this contract, the Buyer may not, for any reason, delay and/or suspend payments for executed orders. In the event of changes in the Buyer's economic conditions, the Seller may request immediate payment with forfeiture of the grace period, change payment terms, including a request for total or partial prepayment before shipment. In any case, the Buyer is not entitled to make offsetting, deductions, or reductions of the price and/or sums due to the Seller, unless there is written consent from the Seller.

## DELIVERY TERMS

Unless otherwise agreed in writing, any indicated delivery term is not binding on the Seller. Unless otherwise agreed between the parties, the indicative delivery term is specified in the order confirmation. The delivery terms and methods of the product and/or spare parts are those indicated by the Seller in the order confirmation; it is understood that the Seller is not responsible for delays due to force majeure, acts of third parties, public authorities, or causes attributable to the Buyer, as expressly regulated in article 1341 of the Civil Code. The Seller is not obligated to accept returns of products unless expressly agreed in writing. Any costs incurred for this purpose are borne by the Buyer.

## WARRANTY TERMS

- a) The Seller guarantees that the products and/or spare parts are free from defects and conform to the technical specifications stated in the product technical manuals and documentation provided to the Buyer.
- b) The warranty is valid for 12 months from the date the Product and/or spare parts and/or Product parts leave the Seller's premises.
- c) The Seller is not liable, even towards third parties, for improper use and non-compliance with what is indicated in the user and maintenance manuals for the products and/or spare parts, as well as for use by untrained personnel.
- d) Tampering with the product and/or spare parts or any maintenance and/or repair work on it, or replacement of parts not authorized in writing by the Seller, results in the forfeiture of the warranty.
- e) It is the Buyer's obligation to check the packaging, quantity, and conformity of the products and/or spare parts at the time of delivery, recording any discrepancies in the Delivery Note.
- f) Any defects or non-conformities of the products and/or spare parts must be reported in writing to the Seller within 8 days of receipt, including a detailed report and photographic documentation of the complaints and a copy of the Delivery Note with the complaints already indicated therein.
- g) Catalogs, price lists, and promotional materials provided by the Seller, containing images and indicative descriptions of the product, cannot be used as evidence of non-compliance with the Product itself.
- h) Once it is verified that the product reported as defective falls within the warranty condition, Malaguti srl may decide how to intervene, ensuring the problem is resolved as quickly as possible.
- i) All products and/or spare parts, even in replacement, or sent before the warranty is verified, will be shipped with a sales Delivery Note and billed to the Buyer. After appropriate checks, in the case of replacement falling within the warranty condition, the Seller will issue a credit note.
- l) This warranty condition does not cover any damages to the Customer or third parties, direct or indirect damages, loss of profits, accidental damages, commercial damages, production delays, damage to reputation, and any other costs incurred by the Buyer and internal management expenses. The warranty also does not cover travel expenses for the shipment of products and/or spare parts.
- m) The Seller reserves the right to send the Buyer a replacement product and/or spare part for the period necessary for any checks and repairs.



#### **LIMITATION OF LIABILITY**

Except in cases of justified dispute, the Buyer is not entitled to any further rights or remedies. In particular, the Seller is not liable for any compensation claimed for breach or non-performance of the contract, for any direct damage, or loss of profit suffered by the Buyer as a result of the use, non-use, or installation of the Products in other products, except in cases covered by warranty as indicated in the previous paragraph or in cases of willful misconduct or gross negligence by the Seller. The Seller will make every effort to deliver the Products within the agreed-upon timeframe, but in no case shall the Seller be held responsible for damages directly or indirectly caused by delayed contract execution or delayed product delivery. The catalog, price list, or other promotional materials of the Seller only serve as an indication of the type of Products and prices, and the indications therein are not binding on the Seller. The Seller assumes no responsibility for errors or omissions in its own price list or promotional materials.

#### **INTELLECTUAL PROPERTY OF MALAGUTI S.R.L.**

The Customer expressly acknowledges that the trademarks, trade names, or other distinctive signs affixed to the goods are the exclusive property of Malaguti s.r.l. and may not be altered, modified, removed, or deleted in any way. The Customer has the limited right to use the trademark, trade names, or other distinctive signs, as well as any other industrial property or production and commercial know-how incorporated in the goods, for the sole and limited purpose of reselling the goods to the public. Any different use of Malaguti s.r.l.'s intellectual property by the Customer, unless expressly granted by Malaguti s.r.l. in writing, shall be deemed a violation by the Customer of the aforementioned exclusive rights of Malaguti s.r.l., also from a contractual liability perspective, and will be properly pursued. Documents, drawings, data, and information (whether in paper form or electronically) that are delivered to the Customer remain the exclusive property of Malaguti s.r.l. and serve as support for a better representation of the Product and are indicative of the Product's performance. The Customer agrees not to reproduce them, disclose them to third parties, and also to take appropriate precautions with respect to its personnel to ensure their protection.

#### **PERSONAL DATA PROCESSING**

- a) The personal data of the Buyer will be processed in accordance with Italian law on personal data processing, including GDPR and Legislative Decree 101/2018 and subsequent amendments. The Seller informs the Buyer that the Seller is the data controller, and the personal data of the Buyer are collected and processed exclusively for the execution of this agreement.
- b) Data and information processed based on these general sales conditions may not in any way be disclosed to third parties, unless expressly authorized in writing by the Seller, except for legal obligations related to providing documents containing personal data to public authorities.
- c) Each Party undertakes to promptly report to the other any violation of trademark rights of which it becomes aware, as well as any other acts of unfair competition committed by third parties, in order to allow the injured Party to take the necessary or appropriate defensive actions in the common interest.

#### **APPLICABLE LAW**

- a) If the Buyer is a legal entity under Italian law, these General Sales Conditions and all contracts entered into by the Buyer with the Seller shall be governed by Italian law.
- b) If, on the other hand, the Buyer is a national of a country other than Italy, these General Sales Conditions and all contracts entered into by the Buyer with the Seller shall be governed by the 1980 United Nations Convention on Contracts for the International Sale of Goods (CISG).

#### **JURISDICTION**

- a) All disputes arising from this contract shall be exclusively submitted to the jurisdiction of the Forlì Court.
- It is understood between the Parties that only the Seller, at its discretion, shall have the right to waive the jurisdiction of the exclusive court as indicated in the preceding paragraph a) to take legal action against the Buyer at its domicile or at the competent court.

#### **GENERAL PROVISIONS**

- a) The invalidity in whole or in part of individual provisions of these General Sales Conditions shall not affect the validity of the remaining provisions.
- b) Any modification or addition to this contract must be made in writing and duly signed by the parties.
- c) These General Sales Conditions are drafted in both Italian and English. In case of interpretative doubts, the Italian version shall prevail.





 **Officine Malaguti SRL**  
Sant'Agata Bolognese (BO)  
Italy

**Ufficio Commerciale**  
 +39 0547 1932186  
 [commerciale@malagutisrl.com](mailto:commerciale@malagutisrl.com)

 Piazza Plauto, 40  
47027 Sarsina (FC)  
Italy

 [www.malagutisrl.com](http://www.malagutisrl.com)

