

STORM WHEEL

VERDICHTERRAD

- > Ideal für Verdichtungsarbeiten
- > Ideal zum Verdichten von Böden oder Auffüllmaterial
- > Die Ausstattung sorgt für einen garantiert homogenen, soliden und dauerhaft festen Untergrund

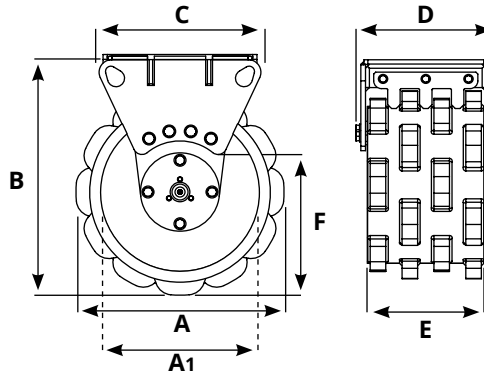

Model	A mm	A1 mm	B mm	C mm	D mm	E mm	F mm	Kg.	Model. PLURY
STORM 40 L200 1/4.5 ton	505	400	595	420	260	200	341	115	W1 9.0 W1 15.0
STORM 40 L300 1/4.5 ton	505	400	595	360	360	300	341	140	W1 9.0 W1 15.0
STORM 40 L400 1/4.5 ton	505	400	595	280	460	400	341	165	W1 9.0 W1 15.0
STORM 40 L500 1/4.5 ton	505	400	595	280	560	500	341	191	W1 9.0 W1 15.0
STORM 50 L300 4/12 ton	615	500	700	430	370	300	393	206	W1 27.0 W1 40.0
STORM 50 L400 4/12 ton	615	500	700	430	470	400	393	235	W1 27.0 W1 40.0
STORM 50 L500 4/12 ton	615	500	700	430	570	500	393	272	W1 27.0 W1 40.0
STORM 50 L600 4/12 ton	615	500	700	430	670	600	393	302	W1 27.0 W1 40.0
STORM 65 L400 8/40 ton	790	650	895	540	485	400	527	363	W1 65.0 W1 95.0 W2 60.0 W2 80.0 W2 100.0 W2 120.0 W2 150.0 W2 180.0
STORM 65 L600 8/40 ton	790	650	895	540	685	600	527	458	
STORM 65 L800 8/40 ton	790	650	895	540	885	800	527	555	
STORM 90 L600 18/40 ton	1045	900	1170	600	700	600	728	662	/
STORM 90 L800 18/40 ton	1045	900	1170	600	900	800	728	775	/
STORM 90 L1000 18/40 ton	1045	900	1170	600	1100	1000	728	895	/

- > Mittels der MASCHINENANSCHLÜSSEN kann das Rad ohne Drehwerk direkt an der Arbeitsmaschine montiert werden

	Model	A mm	B mm	C mm	Kg.
	ADAPTER FOR QUICK COUPLING 1/4.5 ton	/	/	/	/
	ADAPTER FOR QUICK COUPLING 4/12 ton	/	/	/	/
1	ADAPTER FOR QUICK COUPLING 8/14 ton	/	/	/	/
	ADAPTER FOR QUICK COUPLING 12/25 ton	/	/	/	/
	ADAPTER FOR QUICK COUPLING 18/40 ton	/	/	/	/
	FIXED COUPLING MACHINE 1/4.5 ton	/	/	/	/
	FIXED COUPLING MACHINE 4/12 ton	/	/	/	/
2	FIXED COUPLING MACHINE 8/14 ton	/	/	/	/
	FIXED COUPLING MACHINE 12/25 ton	/	/	/	/
	FIXED COUPLING MACHINE 18/40 ton	/	/	/	/
	BOLTED PLATE MACHINE COUPLING 1/2 ton	390	195	10	7
	BOLTED PLATE MACHINE COUPLING 1/4.5 ton	410	235	10	8.5
3	BOLTED PLATE MACHINE COUPLING 4/12 ton	470	280	15	16.5
	BOLTED PLATE MACHINE COUPLING 8/14 ton	640	340	15	29
	BOLTED PLATE MACHINE COUPLING 12/25 ton	710	400	20	48
	BOLTED PLATE MACHINE COUPLING 18/40 ton	920	450	20	70

