

# VORTEX 2

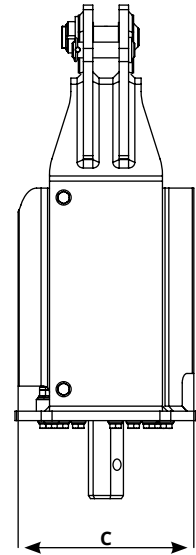

Tons	1.0 - 1.8	1.8 - 2.2	2.0 - 3.0	3.0 - 4.5	4.0 - 6.0	6.0 - 7.5	7.0 - 10.0	10.0 - 15.0	15.0 - 20.0
MODEL	<b>V1</b>	<b>V2</b>	<b>V3</b>	<b>V4</b>	<b>V5</b>	<b>V6</b>	<b>V7</b>	<b>V8</b>	<b>V9</b>
A (mm)	235	235	235	300	300	360	360	410	410
B (mm)	475	475	475	660	660	780	780	950	950
C (mm)	230	230	230	290	290	350	350	430	430
WRENCH	50	50	50	50	50	70	70	70	70
Without coupling weight Kg	59	62	62	100	105	180	180	260	283
Flow rate Min/Max (L/1')	20-30	25-40	30-50	40-60	50-70	60-80	80-90	90-120	110-150
Pressure Bar	220	220	220	220	220	220	220	240	280
Torque Max. N/m	1.200	1.600	2.500	3.500	4.500	6.200	8.000	10.000	15.000

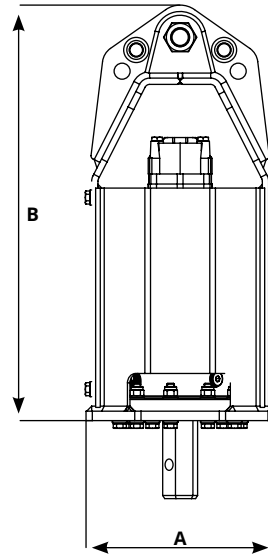

4.2 version



# VORTEX 2F

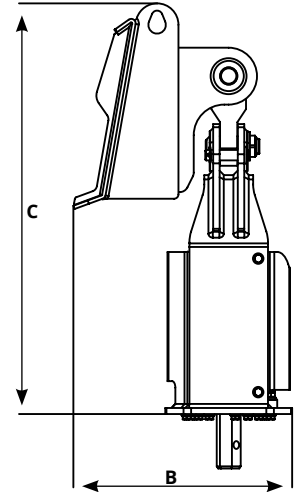
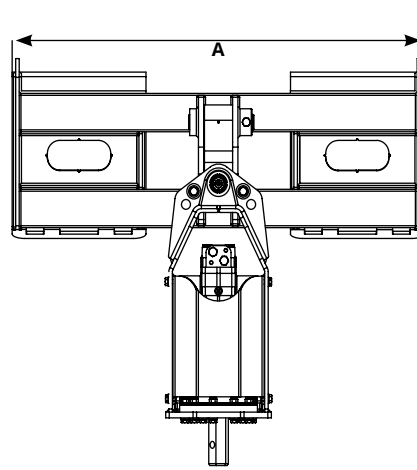

MODEL	V1	V2	V3	V4	V5
A (mm)	1170	1170	1170	1170	1170
B (mm)	470	470	470	500	500
C (mm)	750	750	750	935	935
WRENCH	50	50	50	50	50
Weight with attachment Kg	244	247	247	285	290
Flow rate Min/Max (L/1')	20-30	25-40	30-50	40-60	50-70
Pressure Bar	220	220	220	220	220
Torque Max. N/m	1.200	1.600	2.500	3.500	4.500

Model  
COUPLING TO LOADER  
attachment supplement  
for loaders



4.2 version