

TORNADO

DESTOCONADORA FRONTAL TRANSVERSAL PARA SKID LOADER Y WHEEL LOADER

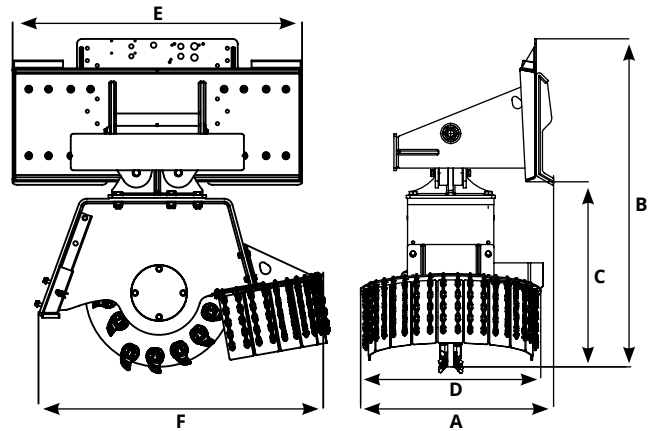

TORNADO 2FT	Tornado 2FT 350	Tornado 2FT 450	Tornado 2FT 600	Tornado 2FT 600 PLUS
A (mm)	720	720	780	780
B (Ømm)	1060	1160	1325	1325
C (mm)	480	570	750	750
D (mm)	610	610	730	730
E (mm)	1170	1170	1170	1170
F (mm)	760	900	1150	1150
Motor (CC)	12 18 25 28 32	25 28 32	45 50 63	80
Flujo de aceite (L/Min)	16 24 32 36 42	32 36 42	56 64 80	110
RPM	1330 1330 1280 1280 1315	1280 1280 1315	1290 1300 1300	1375
Peso (Kg)	246	300	408	408
Numero de dientes	16	20	28	28
Presión (BAR)	250	250	250	250
Presión máxima inversa (BAR)	15	15	15	15

KIT DRAINAGE

HYDRAULIC KIT 4 HOSES + DRAINAGE WITH MOTOR FLOW ADJUSTMENT

HYDRAULIC KIT 4 HOSES + DRAINAGE (adjustment is managed by the host machine)

Model

COUPLING TO LOADER
Supplement for BLADES

