

KIT DRENAJE PLURY
Contrapresión M_áx.
15 BAR

PLURY	W1 9.0 TONS 1.0 - 2.0	W1 15.0 TONS 1.5 - 4.0	W1 15.0 TONS 1.5 - 4.0	W1 15.0 TONS 1.5 - 4.0	W1 27.0 TONS 4.0 - 6.5	W1 27.0 TONS 4.0 - 6.5	W1 27.0 TONS 4.0 - 6.5
A (mm)	480	525	525	525	680	680	680
B (mm)	366	430	430	430	540	540	540
C (mm)	210	210	210	210	272	272	272
D (mm)	290	290	290	290	395	395	395
Peso (Kg)	72	105	105	105	187	187	187
Motor (CC)	11	11	14	17	21	27	32
Flujo de aceite (L/Min)	23	23	31	37	45	57	69
Presión (BAR)	200/220	200/220	200/220	200/220	200/220	200/220	200/220
Frecuencia de vibración (RPM)	2.130	2.130	2.153	2.173	2.133	2.111	2.143
Fuerza centrífuga (Kn)	9	15	15	15	27	27	27
Hertz	35	36	36	36	36	36	36
Contrapresión M _á x. (BAR)	15	15	15	15	15	15	15

PLURY	W1 40.0 TONS 5.0 - 6.5	W1 40.0 TONS 5.0 - 6.5	W1 40.0 TONS 5.0 - 6.5	W1 65.0 TONS 7.0 - 15.0	W1 65.0 TONS 7.0 - 15.0	W1 65.0 TONS 7.0 - 15.0	W1 95.0 TONS 8.0 - 22.0	W1 95.0 TONS 8.0 - 22.0	W1 95.0 TONS 8.0 - 22.0
A (mm)	680	680	680	840	840	840	840	840	840
B (mm)	540	540	540	670	670	670	670	670	670
C (mm)	272	272	272	332	332	332	332	332	332
D (mm)	395	395	395	515	515	515	515	515	515
Peso (Kg)	190	190	190	330	330	330	340	340	340
Motor (CC)	21	27	32	32	43	47	32	43	51
Flujo de aceite (L/Min)	45	57	69	69	93	101	69	93	101
Presión (BAR)	200/220	200/220	200/220	200/220	200/220	200/220	200/220	200/220	200/220
Frecuencia de vibración (RPM)	2.133	2.111	2.143	2.133	2.111	2.143	2.133	2.111	2.143
Fuerza centrífuga (Kn)	40	40	40	65	65	65	95	95	95
Hertz	36	36	36	36	36	36	36	36	36
Contrapresión M _á x. (BAR)	15	15	15	15	15	15	15	15	15

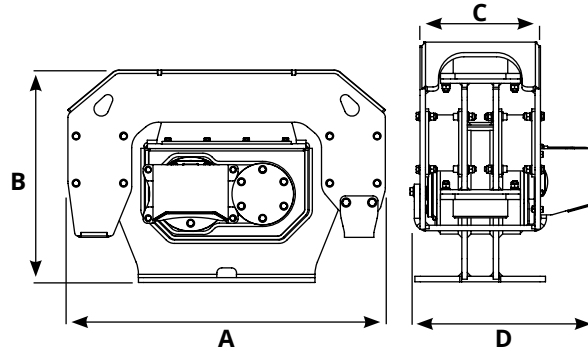

KIT DRENAJE PLURY
Contrapresión Máx.
15 BAR

PLURY	W2 60.0	W2 60.0	W2 60.0	W2 80.0	W2 80.0	W2 80.0	W2 100.0	W2 100.0	W2 100.0
	TONS 8.0 - 14.0	TONS 8.0 - 14.0	TONS 8.0 - 14.0	TONS 10.0 - 15.0	TONS 10.0 - 15.0	TONS 10.0 - 15.0	TONS 12.0 - 18.0	TONS 12.0 - 18.0	TONS 12.0 - 18.0
A (mm)	970	970	970	970	970	970	1030	1030	1030
B (mm)	650	650	650	650	650	650	735	735	735
C (mm)	330	330	330	330	330	330	395	395	395
D (mm)	490	490	490	490	490	490	560	560	560
Peso (Kg)	353	353	353	362	362	362	525	525	525
Motor (CC)	32	43	47	32	43	47	43	47	51
Flujo de aceite (L/Min)	69	93	101	69	93	101	93	100	110
Presión (BAR)	200/220	200/220	200/220	200/220	200/220	200/220	200/220	200/220	200/220
Frecuencia de vibración (RPM)	2.133	2.148	2.143	2.133	2.148	2.143	2.143	2.149	2.157
Fuerza centrífuga (Kn)	60	60	60	80	80	80	100	100	100
Hertz	36	36	36	36	36	36	36	36	36
Contrapresión Máx. (BAR)	15	15	15	15	15	15	15	15	15

PLURY	W2 120.0	W2 120.0	W2 120.0	W2 150.0	W2 180.0
	TONS 14.0 - 20.0	TONS 14.0 - 20.0	TONS 14.0 - 20.0	TONS 18.0 - 35.0	TONS 20.0 - 40.0
A (mm)	1030	1030	1030	1220	1220
B (mm)	735	735	735	920	920
C (mm)	395	395	395	440	440
D (mm)	560	560	560	710	710
Peso (Kg)	533	533	533	827	837
Motor (CC)	43	47	51	63	63
Flujo de aceite (L/Min)	93	100	110	135	135
Presión (BAR)	200/220	200/220	200/220	250/300	250/300
Frecuencia de vibración (RPM)	2.143	2.149	2.157	2.143	2.143
Fuerza centrífuga (Kn)	120	120	120	150	180
Hertz	36	36	36	36	36
Contrapresión Máx. (BAR)	15	15	15	15	15