

ROGNEUSE DE SOUCHES POUR EXCAVATRICE ET RÉTROCHARGEUSE

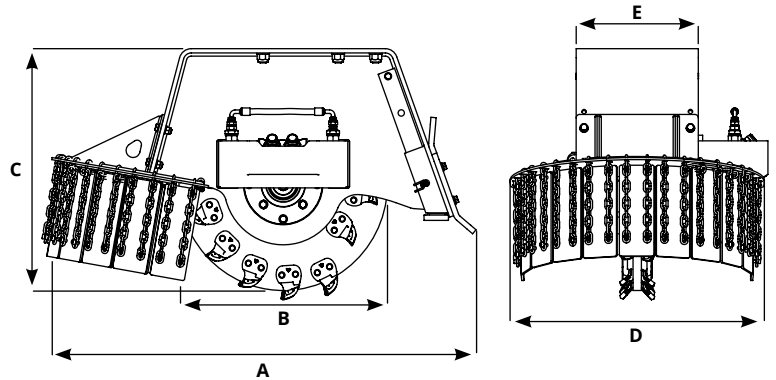

MODEL	Tornado 2 350	Tornado 2 450	Tornado 2 600	Tornado 2 600 PLUS
TONS	1.5 - 4.0	4.0 - 9.0	9.0 - 13.0	13.0 - 18.0
A (mm)	830	970	1230	1230
B (Ømm)	350	450	600	600
C (mm)	430	540	710	710
D (mm)	610	610	730	730
E (mm)	350	350	350	350
Moteur (CC)	12 18 25 28 32	25 28 32	45 50 63	80
Débit d'huile (L/Min)	16 24 32 36 42	32 36 42	56 64 80	110
RPM	1330 1330 1280 1280 1315	1280 1280 1315	1290 1300 1300	1375
Poids (Kg)	116	170	278	278
Numéro de dents	16	20	28	28
Pression (BAR)	250	250	250	250
Contre-pression Max. (BAR)	15	15	15	15

KIT DRAINAGE

TORNADO DRAINAGE KIT Contre-pression MAX 15 BAR

	Model	A mm	B mm	C mm	Kg.
1	ADAPTER FOR QUICK COUPLING for 350	/	/	/	/
	ADAPTER FOR QUICK COUPLING for 450	/	/	/	/
	ADAPTER FOR QUICK COUPLING for 600	/	/	/	/
2	FIXED COUPLING MACHINE for 350	/	/	/	/
	FIXED COUPLING MACHINE for 450	/	/	/	/
	FIXED COUPLING MACHINE for 600	/	/	/	/
3	BOLTED PLATE MACHINE COUPLING for 350	350	280	10	13
	BOLTED PLATE MACHINE COUPLING for 450	380	350	12	17
	BOLTED PLATE MACHINE COUPLING for 600	470	280	15	16.5

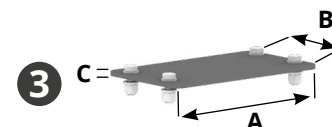



Rogneuse de souches frontale oscillante pour SKID LOADER et WHEEL LOADER

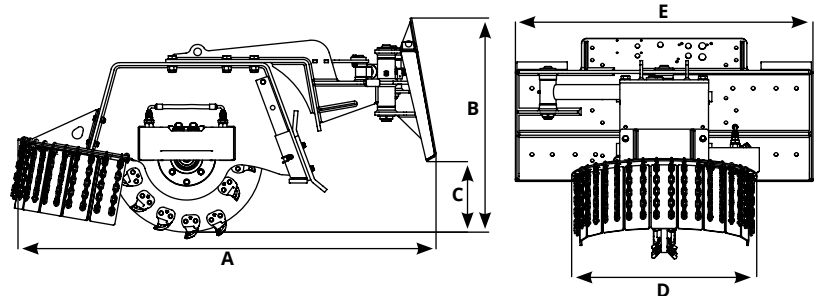
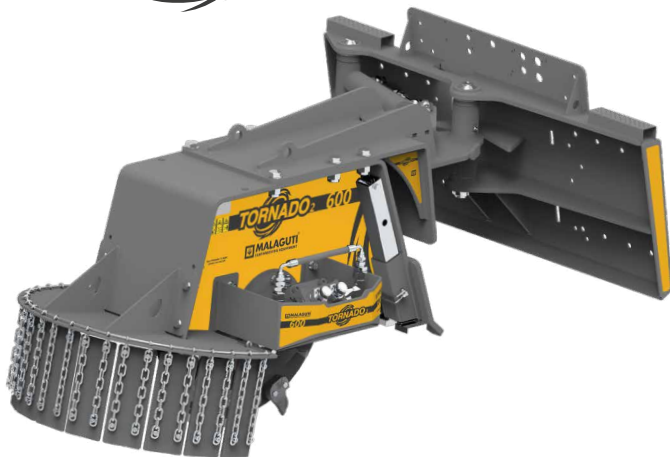

MODEL	Tornado 2F 350	Tornado 2F 450	Tornado 2F 600	Tornado 2F 600 PLUS
A (mm)	1435	1490	1650	1650
B (Ømm)	595	695	860	860
C (mm)	20	120	285	285
D (mm)	610	610	730	730
E (mm)	1170	1170	1170	1170
Moteur (CC)	12 18 25 28 32	25 28 32	45 50 63	80
Débit d'huile (L/Min)	16 24 32 36 42	32 36 42	56 64 80	110
RPM	1330 1330 1280 1280 1315	1280 1280 1315	1290 1300 1300	1375
Poids (Kg)	246	300	408	408
Numéro de dents	16	20	28	28
Pression (BAR)	250	250	250	250
Contre-pression Max. (BAR)	15	15	15	15

KIT DRAINAGE

HYDRAULIC KIT 4 HOSES + DRAINAGE WITH MOTOR FLOW ADJUSTMENT

HYDRAULIC KIT 2 HOSES + DRAINAGE WITH MOTOR FLOW ADJUSTMENT + SWING

HYDRAULIC KIT 4 HOSES + DRAINAGE (Le réglage est géré par la machine opératrice)

Model

COUPLING TO LOADER
supplément pour PALE

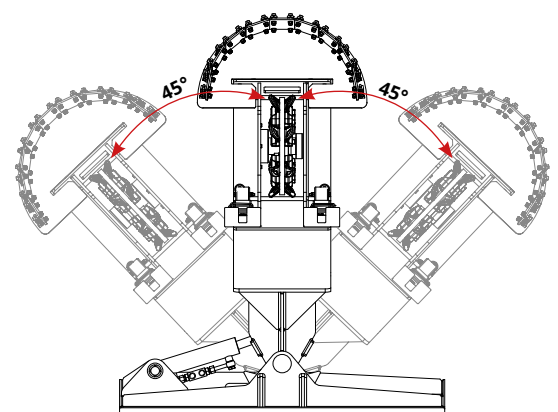

TORNADO



Rogneuse de souches frontale transversale pour SKID LOADER et WHEEL LOADER

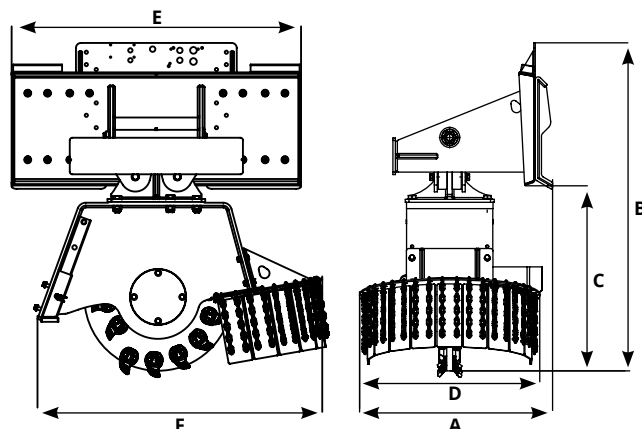

TORNADO 2FT	Tornado 2FT 350	Tornado 2FT 450	Tornado 2FT 600	Tornado 2FT 600 PLUS
A (mm)	720	720	780	780
B (Ømm)	1060	1160	1325	1325
C (mm)	480	570	750	750
D (mm)	610	610	730	730
E (mm)	1170	1170	1170	1170
F (mm)	760	900	1150	1150
Moteur (CC)	12 18 25 28 32	25 28 32	45 50 63	80
Débit d'huile (L/Min)	16 24 32 36 42	32 36 42	56 64 80	110
RPM	1330 1330 1280 1280 1315	1280 1280 1315	1290 1300 1300	1375
Poids (Kg)	246	300	408	408
Numéro de dents	16	20	28	28
Pression (BAR)	250	250	250	250
Contre-pression Max. (BAR)	15	15	15	15

KIT DRAINAGE

HYDRAULIC KIT 4 HOSES + DRAINAGE WITH MOTOR FLOW ADJUSTMENT

HYDRAULIC KIT 4 HOSES + DRAINAGE (Le réglage est géré par la machine opératrice)

Model

COUPLING TO LOADER
supplément pour PALE





Rogneuse de souches frontale transversale pour SKID LOADER et WHEEL LOADER

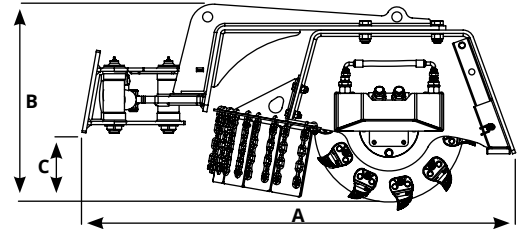
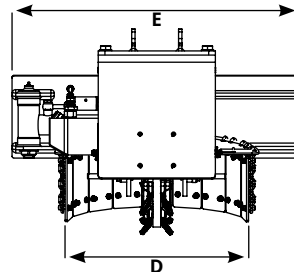

MODEL	Tornado 2M	Tornado 2FM
	350	450
A (mm)	1210	1300
B (Ømm)	490	590
C (mm)	100	200
D (mm)	610	610
E (mm)	865	865
Moteur (CC)	12	25
	18	28
	25	32
	28	
	32	
Débit d'huile (L/Min)	16	32
	24	36
	32	42
	36	
	42	
RPM	1330	1280
	1330	1280
	1280	1315
	1280	
	1315	
Poids (Kg)	166	220
Numéro de dents	16	20
Pression (BAR)	250	250
Contre-pression Max. (BAR)	15	15

KIT DRAINAGE

HYDRAULIC KIT 4 HOSES + DRAINAGE WITH MOTOR FLOW ADJUSTMENT

HYDRAULIC KIT 2 HOSES + DRAINAGE WITH MOTOR FLOW ADJUSTMENT + SWING

HYDRAULIC KIT 4 HOSES + DRAINAGE (Le réglage est géré par la machine opératrice)

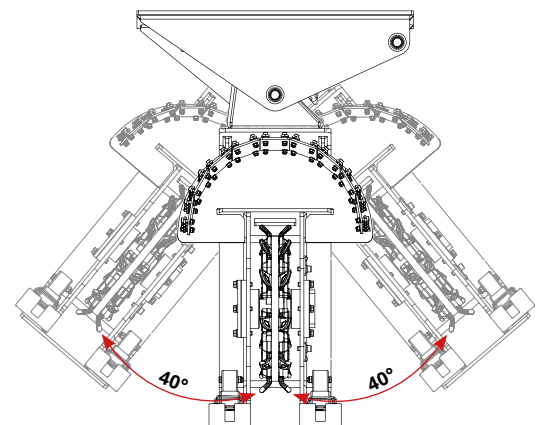

TORNADO SUPPORT FOOT



PIED POUR TORNADO

- › Le pied monté sur la Tornado est indispensable comme support pour se déplacer avec l'excavatrice araignée

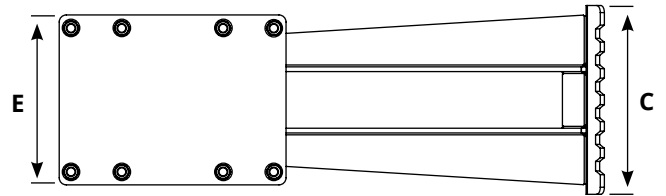
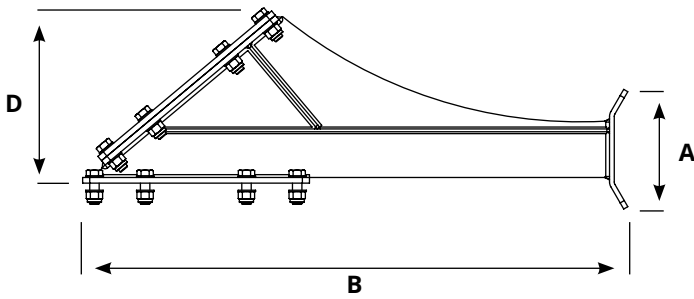

Model	A mm	B mm	C mm	D mm	Kg.	Model
TORNADO SUPPORT FOOT	254	1155	400	365	100	TORNADO 600 TORNADO 600 PLUS

