

ASPHALT CUTTER

COUPE ASPHALTE

- › Idéal pour couper l'asphalte avant de creuser une tranchée

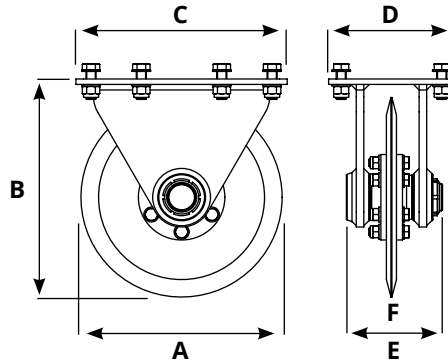

Model	A mm	B mm	C mm	D mm	E mm	F mm	Kg.	Cut. depth mm	Model. PLURY
ASPHALT CUTTER 400 4/12 ton	400	440	420	250	115	12	56	120	W1 27.0 W1 40.0
ASPHALT CUTTER 500 8/40 ton	500	540	540	360	140	12	107	170	W1 65.0 W1 95.0 W2 60.0 W2 80.0 W2 100.0 W2 120.0 W2 150.0 W2 180.0

- › Grâce aux ATTACHES MACHINE, la roue peut être montée directement sur la machine de travail sans propulseur

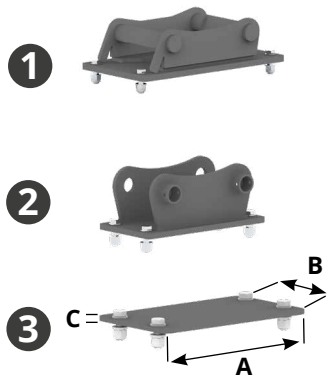

	Model	A mm	B mm	C mm	Kg.
1	ADAPTER FOR QUICK COUPLING 4/12 ton	/	/	/	/
1	ADAPTER FOR QUICK COUPLING 8/14 ton	/	/	/	/
1	ADAPTER FOR QUICK COUPLING 12/25 ton	/	/	/	/
1	ADAPTER FOR QUICK COUPLING 18/40 ton	/	/	/	/
2	FIXED COUPLING MACHINE 4/12 ton	/	/	/	/
2	FIXED COUPLING MACHINE 8/14 ton	/	/	/	/
2	FIXED COUPLING MACHINE 12/25 ton	/	/	/	/
2	FIXED COUPLING MACHINE 18/40 ton	/	/	/	/
3	BOLTED PLATE MACHINE COUPLING 4/12 ton	470	280	15	16.5
3	BOLTED PLATE MACHINE COUPLING 8/14 ton	640	340	15	29
3	BOLTED PLATE MACHINE COUPLING 12/25 ton	710	400	20	48
3	BOLTED PLATE MACHINE COUPLING 18/40 ton	920	450	20	70

