

KIT DRAINAGE PLURY
contre-pression
MAX 15 BAR

PLURY	W2 60.0	W2 60.0	W2 60.0	W2 80.0	W2 80.0	W2 80.0	W2 100.0	W2 100.0	W2 100.0
	TONS 8.0 - 14.0	TONS 8.0 - 14.0	TONS 8.0 - 14.0	TONS 10.0 - 15.0	TONS 10.0 - 15.0	TONS 10.0 - 15.0	TONS 12.0 - 18.0	TONS 12.0 - 18.0	TONS 12.0 - 18.0
A (mm)	970	970	970	970	970	970	1030	1030	1030
B (mm)	650	650	650	650	650	650	735	735	735
C (mm)	330	330	330	330	330	330	395	395	395
D (mm)	490	490	490	490	490	490	560	560	560
Poids (Kg)	353	353	353	362	362	362	525	525	525
Moteur (CC)	32	43	47	32	43	47	43	47	51
Débit d'huile (L/Min)	69	93	101	69	93	101	93	100	110
Pression (BAR)	200/220	200/220	200/220	200/220	200/220	200/220	200/220	200/220	200/220
Fréquence vibration (RPM)	2.133	2.148	2.143	2.133	2.148	2.143	2.143	2.149	2.157
Force centrifuge (Kn)	60	60	60	80	80	80	100	100	100
Hertz	36	36	36	36	36	36	36	36	36
Contre-pression Max. (BAR)	15	15	15	15	15	15	15	15	15

PLURY	W2 120.0	W2 120.0	W2 120.0	W2 150.0	W2 180.0
	TONS 14.0 - 20.0	TONS 14.0 - 20.0	TONS 14.0 - 20.0	TONS 18.0 - 35.0	TONS 20.0 - 40.0
A (mm)	1030	1030	1030	1220	1220
B (mm)	735	735	735	920	920
C (mm)	395	395	395	440	440
D (mm)	560	560	560	710	710
Poids (Kg)	533	533	533	827	837
Moteur (CC)	43	47	51	63	63
Débit d'huile (L/Min)	93	100	110	135	135
Pression (BAR)	200/220	200/220	200/220	250/300	250/300
Fréquence vibration (RPM)	2.143	2.149	2.157	2.143	2.143
Force centrifuge (Kn)	120	120	120	150	180
Hertz	36	36	36	36	36
Contre-pression Max. (BAR)	15	15	15	15	15

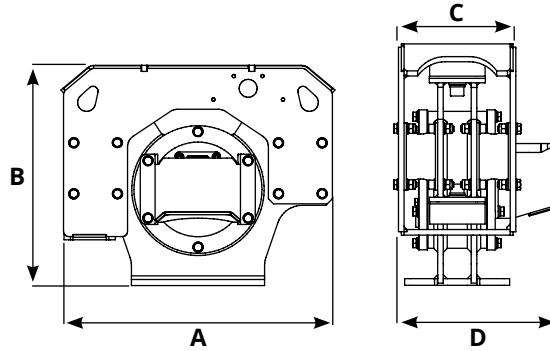

KIT DRAINAGE PLURY
contre-pression
MAX 15 BAR

PLURY	W1 9.0 TONS 1.0 - 2.0	W1 15.0 TONS 1.5 - 4.0	W1 15.0 TONS 1.5 - 4.0	W1 15.0 TONS 1.5 - 4.0	W1 27.0 TONS 4.0 - 6.5	W1 27.0 TONS 4.0 - 6.5	W1 27.0 TONS 4.0 - 6.5
A (mm)	480	525	525	525	680	680	680
B (mm)	366	430	430	430	540	540	540
C (mm)	210	210	210	210	272	272	272
D (mm)	290	290	290	290	395	395	395
Poids (Kg)	72	105	105	105	187	187	187
Moteur (CC)	11	11	14	17	21	27	32
Débit d'huile (L/Min)	23	23	31	37	45	57	69
Pression (BAR)	200/220	200/220	200/220	200/220	200/220	200/220	200/220
Fréquence vibration (RPM)	2.130	2.130	2.153	2.173	2.133	2.111	2.143
Force centrifuge (Kn)	9	15	15	15	27	27	27
Hertz	35	36	36	36	36	36	36
Contre-pression Max. (BAR)	15	15	15	15	15	15	15

PLURY	W1 40.0 TONS 5.0 - 6.5	W1 40.0 TONS 5.0 - 6.5	W1 40.0 TONS 5.0 - 6.5	W1 65.0 TONS 7.0 - 15.0	W1 65.0 TONS 7.0 - 15.0	W1 65.0 TONS 7.0 - 15.0	W1 95.0 TONS 8.0 - 22.0	W1 95.0 TONS 8.0 - 22.0	W1 95.0 TONS 8.0 - 22.0
A (mm)	680	680	680	840	840	840	840	840	840
B (mm)	540	540	540	670	670	670	670	670	670
C (mm)	272	272	272	332	332	332	332	332	332
D (mm)	395	395	395	515	515	515	515	515	515
Poids (Kg)	190	190	190	330	330	330	340	340	340
Moteur (CC)	21	27	32	32	43	47	32	43	51
Débit d'huile (L/Min)	45	57	69	69	93	101	69	93	101
Pression (BAR)	200/220	200/220	200/220	200/220	200/220	200/220	200/220	200/220	200/220
Fréquence vibration (RPM)	2.133	2.111	2.143	2.133	2.111	2.143	2.133	2.111	2.143
Force centrifuge (Kn)	40	40	40	65	65	65	95	95	95
Hertz	36	36	36	36	36	36	36	36	36
Contre-pression Max. (BAR)	15	15	15	15	15	15	15	15	15

PLATE

PLAQUE DE COMPACTAGE

- › Conçue pour compacter tous les types de surfaces telles que les tranchées, les sols, les pentes
- › Elle garantit une base compacte, homogène et stable qui dure dans le temps
- › Capable de compacter dans des positions très difficiles

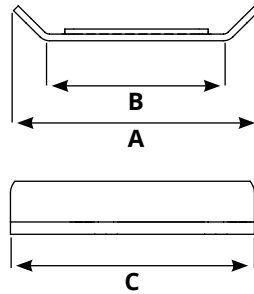
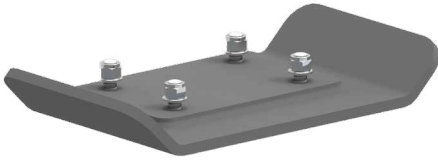

Model	A mm	B mm	C mm	Kg.	compaction kg cm2		Model. PLURY
PLATE 300 1/4 ton	550	400	300	30	W1 9.0 > 0.75	W1 15.0 > 1.25	W1 9.0 W1 15.0
PLATE 400 1/4 ton	550	400	400	40	W1 9.0 > 0.56	W1 15.0 > 0.93	W1 9.0 W1 15.0
PLATE 590 1.5/4 ton	550	400	590	59	W1 15.0 > 0.63		W1 15.0
PLATE 690 1.5/4 ton	550	400	690	69	W1 15.0 > 0.54		W1 15.0
PLATE 400 4/6.5 ton	700	500	400	60	W1 27.0 > 1.35	W1 40.0 > 2	W1 27.0 W1 40.0
PLATE 500 4/6.5 ton	700	500	500	75	W1 27.0 > 1.08	W1 40.0 > 1.6	W1 27.0 W1 40.0
PLATE 690 4/6.5 ton	700	500	690	100	W1 27.0 > 0.78	W1 40.0 > 1.15	W1 27.0 W1 40.0
PLATE 790 4/6.5 ton	700	500	790	115	W1 27.0 > 0.68	W1 40.0 > 1	W1 27.0 W1 40.0
PLATE 890 4/6.5 ton	700	500	890	130	W1 40.0 > 0.89		W1 40.0
PLATE 550 7/15 ton	1030	820	550	111	W1 65.0 > 1.44	W1 95.0 > 2.21	W1 65.0 W1 95.0 W2 60.0 W2 80.0
					W2 60.0 > 1.53	W2 80.0 > 1.77	
PLATE 600 7/15 ton	1030	820	600	121	W1 65.0 > 1.32	W1 95.0 > 2.03	W1 65.0 W1 95.0 W2 60.0 W2 80.0
					W2 60.0 > 1.21	W2 80.0 > 1.62	
PLATE 700 7/15 ton	1030	820	700	141	W1 65.0 > 1.13	W1 95.0 > 1.74	W1 65.0 W1 95.0 W2 60.0 W2 80.0
					W2 60.0 > 1.04	W2 80.0 > 1.39	
PLATE 890 7/15 ton	1030	820	890	180	W1 65.0 > 0.89	W1 95.0 > 1.37	W1 65.0 W1 95.0 W2 60.0 W2 80.0
					W2 60.0 > 0.82	W2 80.0 > 0.98	
PLATE 990 7/15 ton	1030	820	990	200	W1 65.0 > 0.80	W1 95.0 > 1.23	W1 65.0 W1 95.0 W2 60.0 W2 80.0
					W2 60.0 > 0.73	W2 80.0 > 0.89	
PLATE 600 12/20 ton	1110	900	600	160	W2 100.0 > 1.85	W2 120.0 > 2.22	W2 100.0 W2 120.0
PLATE 700 12/20 ton	1110	900	700	185	W2 100.0 > 1.58	W2 120.0 > 1.90	W2 100.0 W2 120.0
PLATE 800 12/20 ton	1110	900	800	205	W2 100.0 > 1.38	W2 120.0 > 1.53	W2 100.0 W2 120.0
PLATE 750 18/40 ton	1270	1060	750	220	W2 150.0 > 1.88	W2 180.0 > 2.26	W2 150.0 W2 180.0
PLATE 850 18/40 ton	1270	1060	850	250	W2 150.0 > 1.66	W2 180.0 > 1.99	W2 150.0 W2 180.0

