

# ASPHALT CUTTER

## COUPE ASPHALTE

- › Idéal pour couper l'asphalte avant de creuser une tranchée

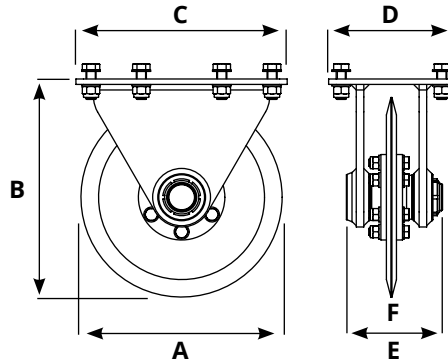

Model	A mm	B mm	C mm	D mm	E mm	F mm	Kg.	Model. PLURY
ASPHALT CUTTER 400 4/12 ton	400	440	420	250	115	12	56	<b>W1 27.0   W1 40.0</b>
ASPHALT CUTTER 500 8/40 ton	500	540	540	360	140	12	107	<b>W1 65.0   W1 95.0   W2 60.0 W2 80.0   W2 100.0   W2 120.0 W2 150.0   W2 180.0</b>

- › Grâce aux ATTACHES MACHINE, la roue peut être montée directement sur la machine de travail sans propulseur

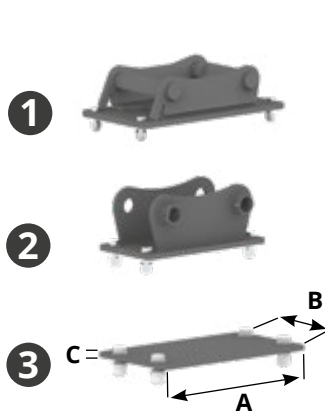

1  
2  
3

Model	A mm	B mm	C mm	Kg.
ADAPTER FOR QUICK COUPLING 4/12 ton	/	/	/	/
ADAPTER FOR QUICK COUPLING 8/14 ton	/	/	/	/
ADAPTER FOR QUICK COUPLING 12/25 ton	/	/	/	/
ADAPTER FOR QUICK COUPLING 18/40 ton	/	/	/	/
FIXED COUPLING MACHINE 4/12 ton	/	/	/	/
FIXED COUPLING MACHINE 8/14 ton	/	/	/	/
FIXED COUPLING MACHINE 12/25 ton	/	/	/	/
FIXED COUPLING MACHINE 18/40 ton	/	/	/	/
BOLTED PLATE MACHINE COUPLING 4/12 ton	470	280	15	16.5
BOLTED PLATE MACHINE COUPLING 8/14 ton	640	340	15	29
BOLTED PLATE MACHINE COUPLING 12/25 ton	710	400	20	48
BOLTED PLATE MACHINE COUPLING 18/40 ton	920	450	20	70

